



3-phase Sensor-less Motor Driver AM2825N

● Features and Benefit

- Wide operation voltage 1.8 to 6.0V
- Low Quiescent Current
- Maximum output current 2A
- Lock detection/Automatic restart function
- Soft switching technique to reduce acoustic noise
- Forward and Reverse control
- Built-in FG (frequency generation)
- Built-in RD (Rotate Detect)
- Thermal shutdown protection
- Over current Limiter
- PWM speed control
- Pb-Free and Halogen-Free Green product

● Description

The AM2825N is a 3-phase sensor-less DC motor driver IC. It senses the BEMF (Back Electro-Motive Force) of the motor in rotation and provides corresponding commutation current to the motor. Rotation speed can be controlled by PWM input signal.

The drivers include Lock Detection, Thermal Shutdown, and Over-Current Limiter. Forward and Reverse control.

Package material is Pb-Free and Halogen-Free (Green) for the purpose of environmental protection and for sustainable development of the Earth.

● Applications

- 3-phase sensor-less DC Motor
- Electric shaver
- ASIC Cooling Fans

● Ordering Information

Orderable Part Number	Package	Marking
AM2825N	QFN 4X4	A2825

● **Absolute Maximum Ratings (Ta=25°C)**

Parameter	Symbol	Limits	Unit
Supply voltage	V _{CC}	6.5	V
Power MOS supply voltage	V _M	V _{CC}	V
Output current	I _{omax}	2000*	mA
FG/ RD signal output voltage	V _{FG} / V _{RD}	6.5	V
FG/ RD signal output current	I _{FG} / I _{RD}	10	mA
PWM input voltage	V _{PWMmax}	V _{CC}	V
Power dissipation	P _d	3710**	mW
Operate temperature range	T _{opr}	-40 ~ +125	°C
Storage temperature range	T _{stg}	-55 ~ +150	°C
Junction temperature	T _{jmax}	150	°C

* This value is not to exceed P_d.

**P_d de-rated by 29.68mW/°C over 25°C (based on JEDEC 2S2P board)

**Those are stress rating only and functional operating at those conditions for extended periods may Damage to the device.

● **Recommended operating conditions (Ta=25°C)**

(Set the power supply voltage taking allowable dissipation into considering)

Parameter	Symbol	Min	Typ	Max	Unit
Operating supply voltage range	V _{CC}	1.8 ~ 6.0			V

● Electrical Characteristics

(Unless otherwise specified, $T_a = 25^\circ\text{C}$, $V_{CC} = V_M = 5.0\text{V}$)

Parameter	Symbol	Limit			Unit	Conditions
		Min	Typ	Max		
Supply current	I_{CC}	—	1.8	3	mA	PWM pin= VCC
Stand-by current	I_{SC}	—	6.8	13.5	μA	PWM pin= 0V
Oscillator						
OSC pin charge current	I_{OSC1}	-10.4	-12.5	-14.6	μA	OSC pin= 0.3V
OSC pin discharge current	I_{OSC2}	10.4	12.5	14.6	μA	OSC pin= 1.5V
FR/PWM input						
Input H level	V_{PWMH}	2.5	—	V_{CC}	V	
Input L level	V_{PWML}	0	—	$V_{CC} \cdot 0.2$	V	
PWM input frequency	F_{PWM}	20	—	50	kHz	
Output						
Output ON resistance	$R_{ON(H+L)}$	—	0.7	1.0	Ω	$I_O = 600\text{mA}$ (Upper +Lower)
FG/ RD low voltage	$V_{FGL} / V_{RD L}$	—	—	0.4	V	$I_{FG} / I_{RD} = 5\text{mA}$
FG/ RD leakage current	I_{FGH} / I_{RDH}	—	—	10	μA	$V_{FG} / V_{RD} = 5\text{V}$
Lock protection						
Lock detection ON time	T_{ON}	0.7	1.0	1.3	sec	$T_{ON} = \text{start time} + \text{lock detect}$
Lock detection OFF time	T_{OFF}	3.5	5.0	6.5	sec	
Thermal						
Thermal shutdown	T_{hSD}	150	170	—	$^\circ\text{C}$	*1
Thermal shutdown hysteresis	ΔT_{hSD}		25		$^\circ\text{C}$	*1

*1: It is design target, not to be measured at production test.

● Block Diagram

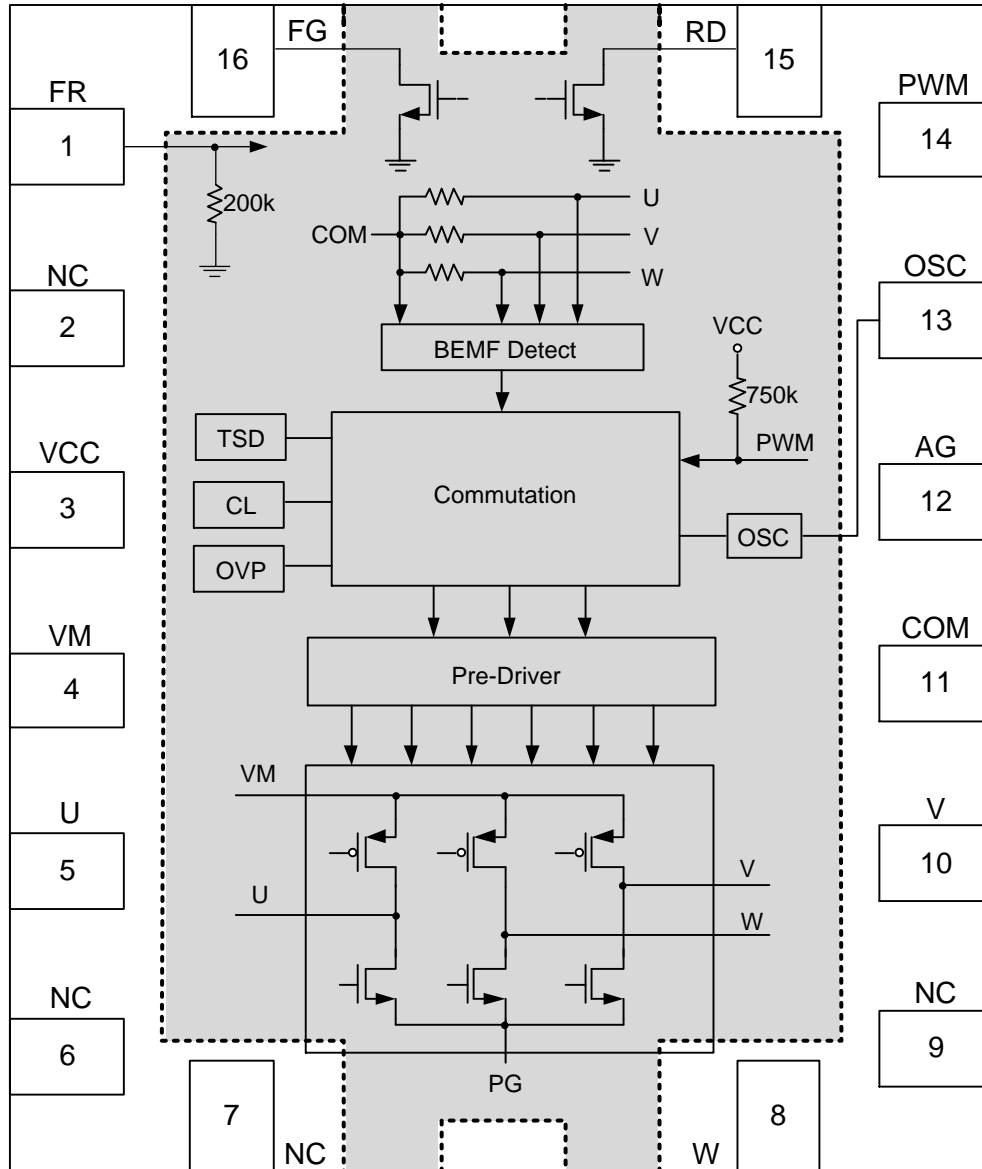

● Pin Configuration

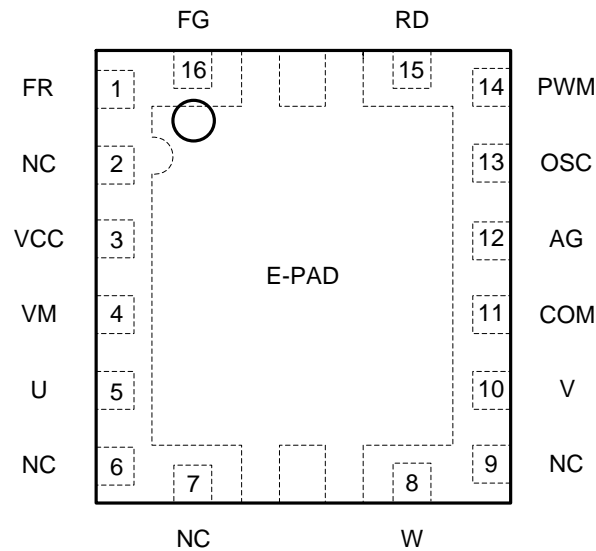

● Pin Descriptions

PIN No	Pin Name	Function	PIN No	Pin Name	Function
1	FR	Forward and Reverse input terminal	9	NC	No connect
2	NC	No connect	10	V	V phase output terminal
3	VCC	Power supply terminal	11	COM	Motor center tap voltage input terminal
4	VM	Power MOS supply terminal	12	AG	Analog ground terminal
5	U	U phase output terminal	13	OSC	Start-up frequency output terminal
6	NC	No connect	14	PWM	PWM signal input terminal
7	NC	No connect	15	RD	RD signal output terminal
8	W	W phase output terminal	16	FG	FG signal output terminal
E-pad	-	ground terminal			

● Thermal Information

Θ_{ja}	junction-to-ambient thermal resistance	33.69°C/W
Ψ_{jt}	junction-to-top characterization parameter	0.1°C/W

- **Θ_{ja}** is obtained in a simulation on a JEDEC-standard 2s2p board as specified in JESD-51.
- The **Θ_{ja}** number listed above gives an estimate of how much temperature rise is expected if the device was mounted on a standard JEDEC board.
- When mounted on the actual PCB, the **Θ_{ja}** value of JEDEC board is totally different than the **Θ_{ja}** value of actual PCB.
- **Ψ_{jt}** is extracted from the simulation data to obtain **Θ_{ja}** using a procedure described in JESD-51, which estimates the junction temperature of a device in an actual PCB.
- The thermal characterization parameter, **Ψ_{jt}**, is proportional to the temperature difference between the top of the package and the junction temperature. Hence, it is useful value for an engineer verifying device temperature in an actual PCB environment as described in JEDEC JESD-51-12.
- When Greek letters are not available, **Ψ_{jt}** is written Psi-jt.
- Definition:

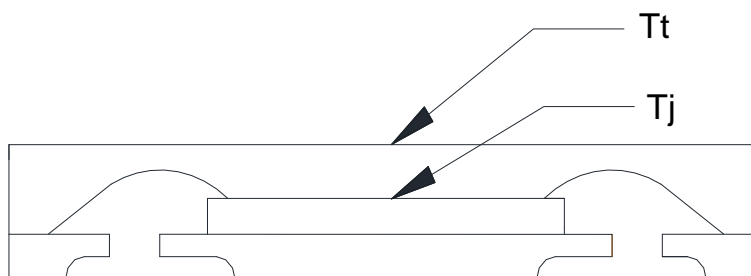

$$\text{DEFINITION: } \Psi_{jt} = (T_j - T_t) / P_d$$

Where :

Ψ_{jt} (Psi-jt) = Junction-to-Top(of the package) °C/W

T_j= Die Junction Temp. °C

T_t= Top of package Temp at center. °C

P_d= Power dissipation. Watts

- Practically, most of the device heat goes into the PCB, there is a very low heat flow through top of the package, So the temperature difference between **T_j** and **T_t** shall be small, that is any error caused by PCB variation is small.
- This constant represents that **Ψ_{jt}** is completely PCB independent and could be used to predict the **T_j** in the environment of the actual PCB if **T_t** is measured properly.

● How to predict Tj in the environment of the actual PCB

Step 1 : Used the simulated Ψ_{jt} value listed above.

Step 2 : Measure Tt value by using

➤ **Thermocouple Method**

We recommend use of a small ~40 gauge(3.15mil diameter) thermocouple. The bead and thermocouples wires should touch the top of the package and be covered with a minimal amount of thermally conductive epoxy. The wires should be heat-insulated to prevent cooling of the bead due to heat loss into wires. This is important towards preventing “too cool” Tt measurements, which would lead to the calculated Tj also being too cool.

➤ **IR Spot Method**

An IR Spot method should be utilized only when using a tool with a small enough spot area to acquire the true top center “hot spot”.

Many so-called “small spot size” tools still have a measurement area of 0~100+mils at “zero” distance of the tool from the surface. This spot area is too big for many smaller packages and likely would result in cooler readings than the small thermocouple method. Consequently, to match between spot area and package surface size is important while measuring Tt with IR sport method.

Step 3 : calculating power dissipation by

$$P \cong (VCC - |V_{o_Hi} - V_{o_Lo}|) \times I_{out} + VCC \times I_{cc}$$

Step 4 : Estimate Tj value by

$$T_j = \Psi_{jt} \times P + T_t$$

Step 5: Calculated Θ_{ja} value of actual PCB by the known Tj

$$\Theta_{ja}(\text{actual}) = (T_j - T_a) / P$$

Maximum Power Dissipation (de-rating curve) under JEDEC PCB & actual PCB

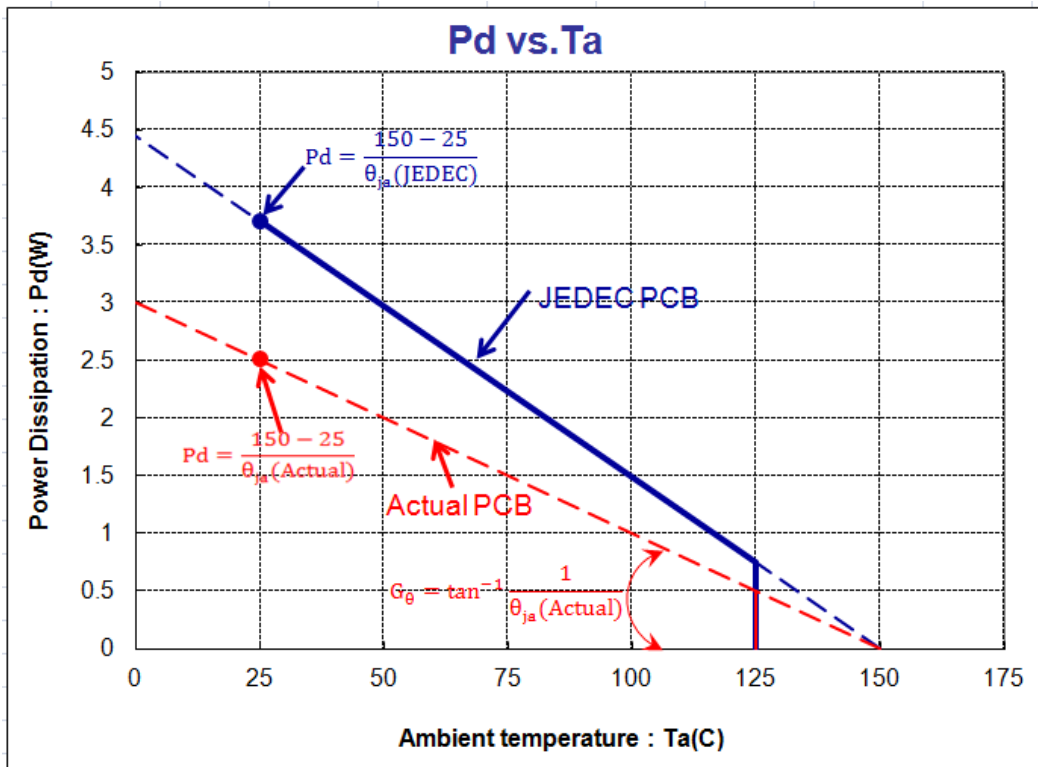

● Application Circuit

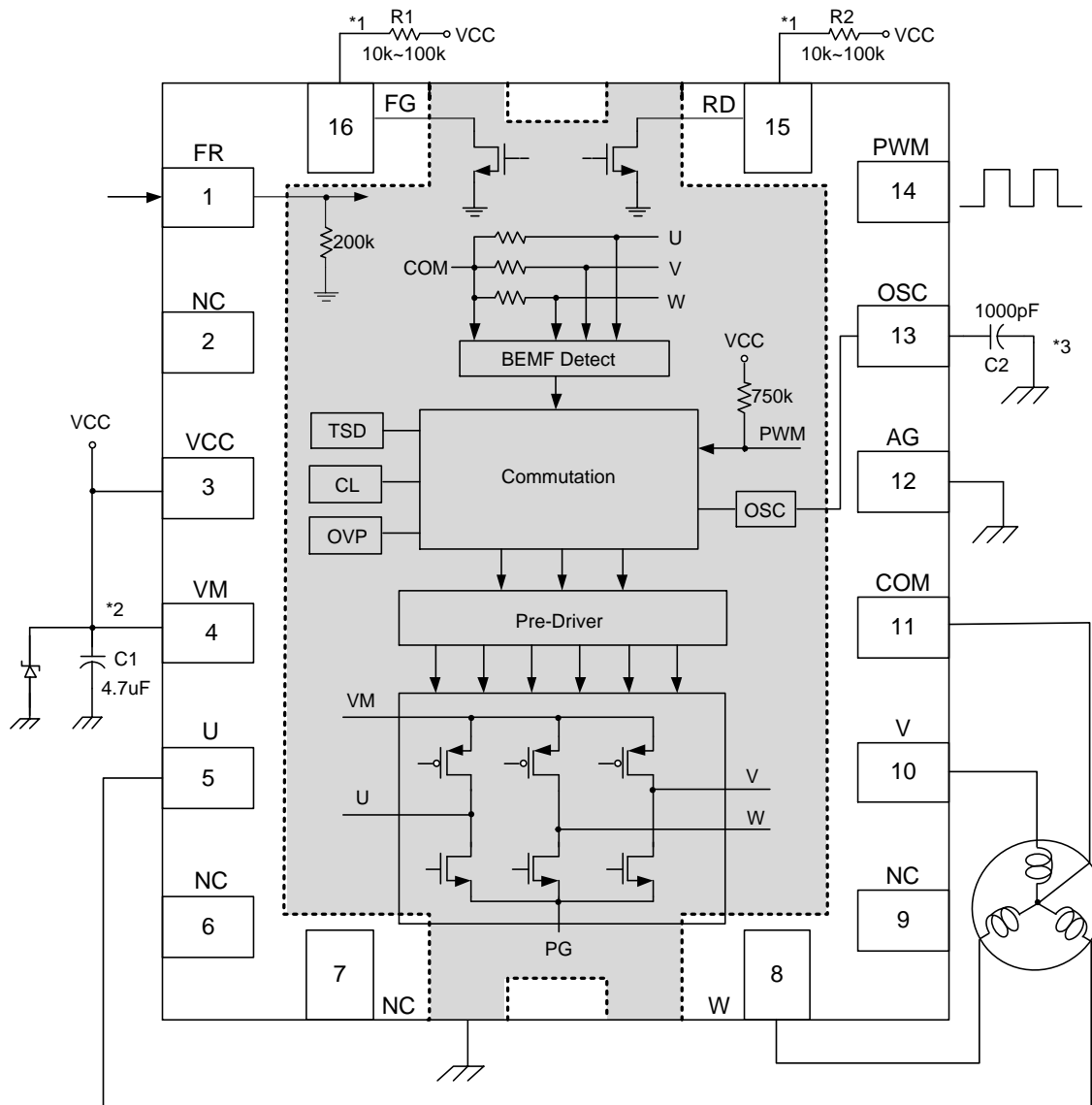

- *1. Open drain output. A pull-up resistance of 10k~100kΩ should be inserted.
- *2. The wiring patterns from the VCC and VM terminal and GND terminal to the bypass capacitor must be routed as short as possible. With respect to the wiring pattern
Add Zener Diode to avoid power over stress or noise large than the absolute maximum voltage.
- *3. This Capacitor 1000pF is only for reference. Variable Motors should select suitable capacitor for optimum start-up characteristics.

● Operation notes

1) Power supply line

The BEMF causes re-circulate current to power supply, please connect a capacitor between power supply and ground as a route of re-circulate current. And please determine the capacitance after confirmation that the capacitance does not causes any problems. If re-circulate current is large, connect the Zener Diode to avoid power over stress damage the IC or MCU.

2) Ground potential

Ground potential AG pin connect the lowest voltage on the chip and short the path as possible. E-pad need connects to AG.

3) PWM speed control

This IC offer PWM pin direct control output transistors for motor speed control. Higher frequency will reduce output current noise. The control input frequency recommended operation between 20 KHz to 50 KHz. If PWM Low is slower than 160us (typ.), it will go into stand-by mode.

This pin connect internal pull-high resistor 750K ohm. When connect to VCC or floating. The motor will rotate in the full speed.

4) Soft Switching Circuit

This IC use duty-variable switching for low acoustic noise and vibration.

5) Start-up Circuits

The OSC pin is defined a sensor-less start-up commutation frequency. The connecting capacitor is between the OSC pin and ground. Variable motors start-up characteristic are variable with different capacitors. Variable motors should select suitable capacitor for optimum start-up characteristics. If the capacitance value is larger, the variation start-up time is longer. Also, if the capacitance value is smaller, the motor start-up time is shorter and might cause start-up failed by motor friction.

6) Start-up Test

In order to make sure start-up normally, after choose OSC capacitor value, it should test every PWM Duty for start-up. Normal start-up test would test PWM Duty 100%~20%, every 5% PWM duty step for each point, make sure start-up status.

Even the motor Coil (U, V, W) BEMF are meet the condition as motor BEMF Requirement, it still need to do the start-up test to verify the start-up status.

7) Current limit

The IC internal built in Over current limit comparator voltage 75mV (typ.).

It sense IC E-Pad pin bonding wire and PCB to AG pin resistors.

$$I_{\text{limit}} = 0.075 / (R_{\text{wire}} + R_{\text{ext}}) = 0.075 / (0.026 + R_{\text{ext}})$$

8) FG (Function Generator) function

This FG pin is made up with an open drain output.

Recommend connect a resistance of 10k~100k ohm to VCC.

9) RD (Rotate Detect) function

The RD pin defines rotate detection. When motor at rotate, the RD defines Low level. When motor at lock or standby mode, the RD defines High level through external pull Hi resistor to power supply. This RD pin is made up with an open drain output. Recommend connect a resistance of 10k~100k ohm to VCC.

10) Thermal design and Thermal shutdown

The thermal design should allow enough margins for actual power dissipation. In case the IC is left running over the allowable loss, the junction temperature rises, and the thermal-shutdown circuit works at the junction temperature of 170°C (typ.) (the outputs of all the channels are turned off). When the junction temperature drops to 145°C (typ.), the IC start operating again

11) FR (Forward and Reverse) function

This pin connect internal pull-low resistor 200K ohm. When floating, it defines Low level. For noise consideration, please connect to Ground or VCC.

FR Function could switch motor from one direction to another. FR=High: U → V → W; FR=Low: U → W → V. Motor could rotate forward and reverse by switching FR voltage level. Need to make sure the motor can switch normally. When switch motor from one direction to another. The rotation speed might too low to affect BEMF to cause lock or inertia to cause wrong rotation direction.

Countermeasure: Setting PWM=Low before FR switch to another level. After motor complete stop rotation (different motors have different rotation stop time). PWM could start control. Please refer the control wave as the following:

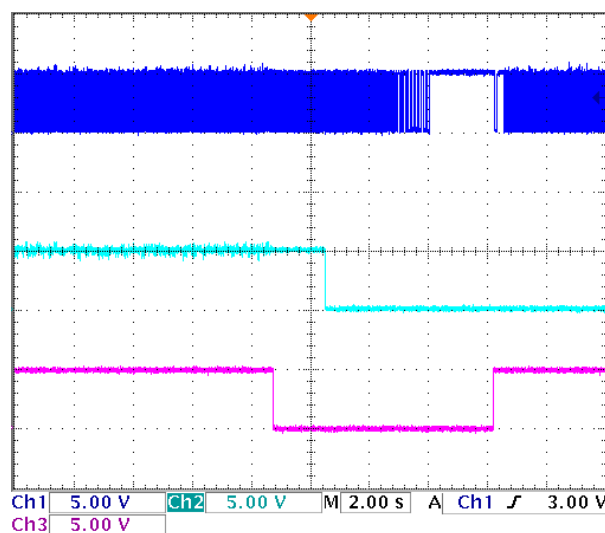
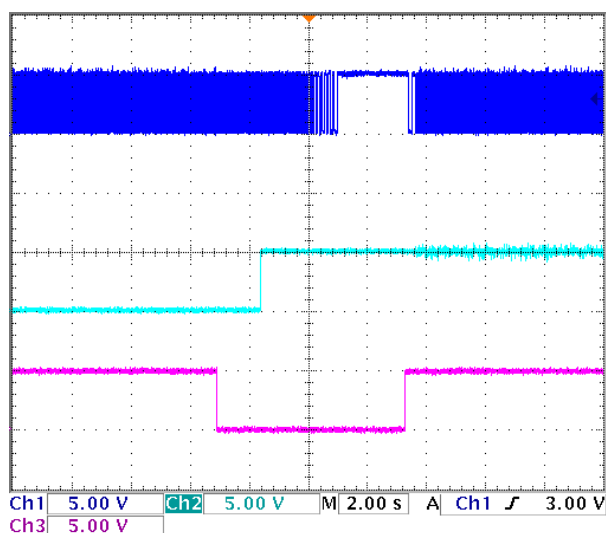

CH1: FG CH2: FR CH3: PWM

12) Motor BEMF Requirement

- Motor Coil (U, V, W) BEMF reference wave define at 1000rpm.
- 1. Motor Coil (U, V, W) BEMF amplitude minimum need to over 40mV.
- 2. Motor Coil (U, V, W) BEMF Zero Cross Slope need equal or greater than reference SINE wave within $\pm 15\text{mV}$.

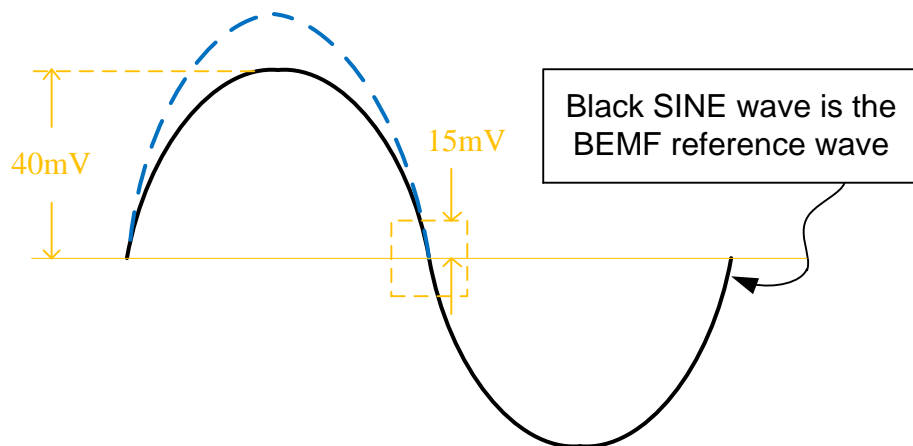

3. Acceptable

- A. BEMF wave greater than 40mV
- B. BEMF wave greater than 40mV. The wave middle side need to greater than $\pm 20\text{mV}$.

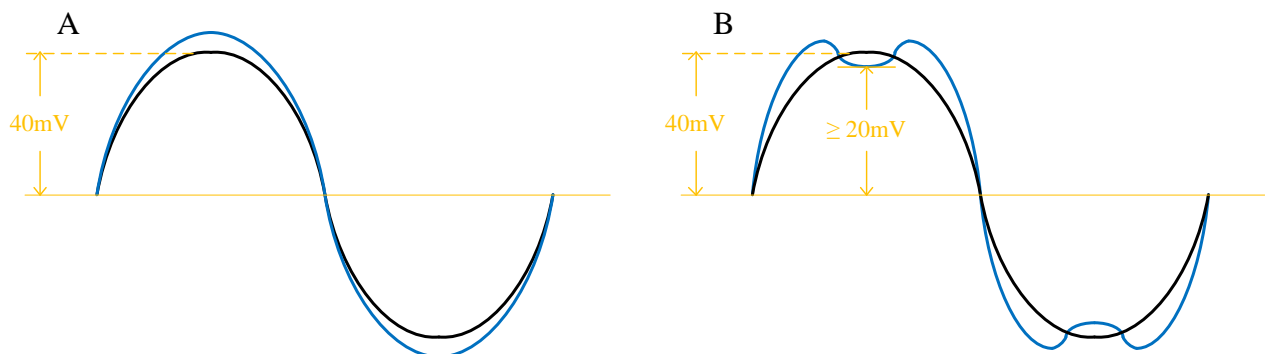

4. Unacceptable

- C. BEMF wave smaller than 40mV.
- D. BEMF Zero Cross Slope less than reference SINE wave within $\pm 15\text{mV}$.

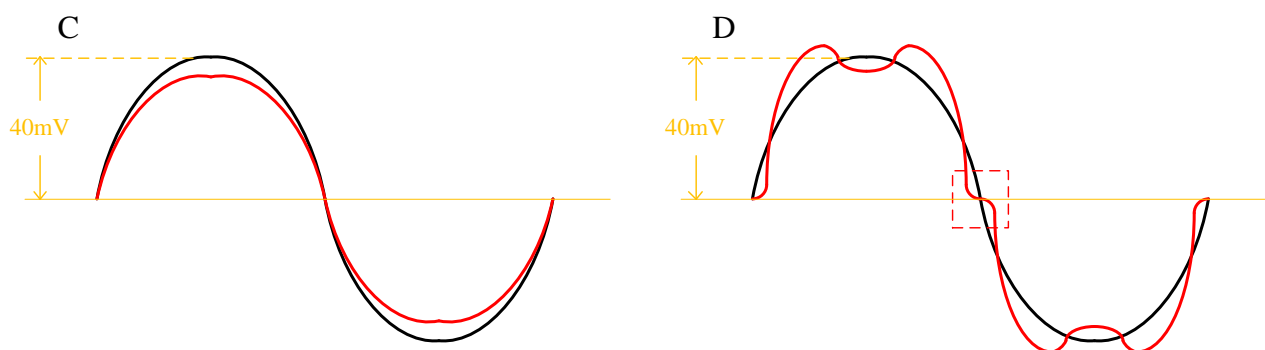

- **Condition of Soldering**

- 1).Manual Soldering

Pb-free: Time / Temperature \leq 3 sec / $390 \pm 10^\circ\text{C}$ (2 Times)

Test Results : 0 fail/ 22 tested

Manual Soldering count : 2 Times

- 2).Re-flow Soldering (follow IPC/JEDEC J-STD-020D)

Classification Reflow Profile

Profile Feature	Pb-Free Assembly
Average ramp-up rate (T_L to T_P)	$3^\circ\text{C}/\text{second}$ max.
Preheat	
- Temperature Min ($T_{s\ min}$)	150°C
- Temperature Max ($T_{s\ max}$)	200°C
- Time (min to max) (t_s)	60-120 seconds
$T_{s\ max}$ to T_L	
- Temperature Min ($T_{s\ min}$)	$3^\circ\text{C}/\text{second}$ max.
Time maintained above:	
- Temperature (T_L)	217°C
- Time (t_L)	60-150 seconds
Peak Temperature (T_P)	$260 +0/-5^\circ\text{C}$
Time with 5°C of actual Peak	30 seconds
- Temperature (t_p)	
Ramp-down Rate	$6^\circ\text{C}/\text{second}$ max.
Time 25°C to Peak Temperature	8 minutes max.

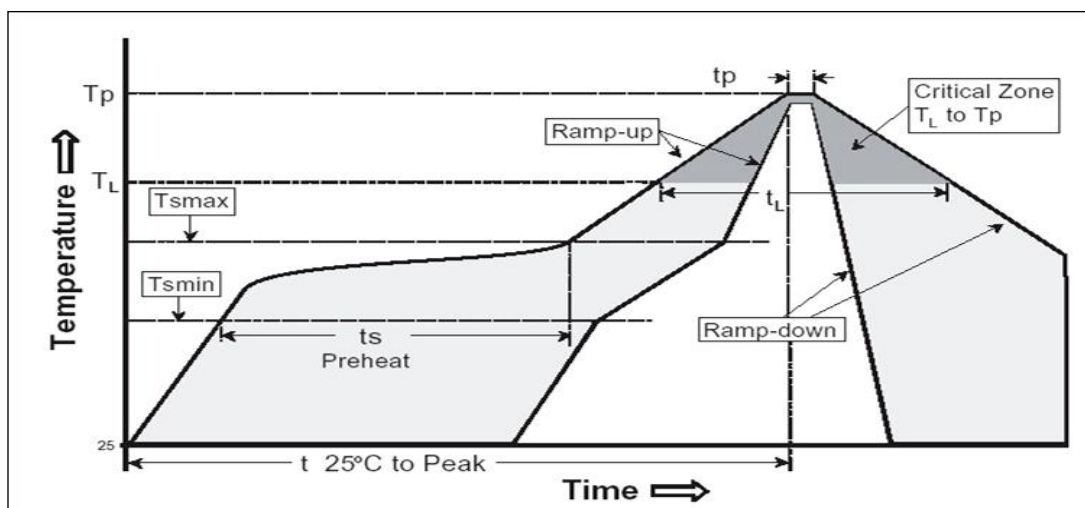

- Test Results : 0 fail/ 32 tested
- Reflow count : 3 cycles

● Packaging outline --- QFN 4x4-16L

Unit : mm

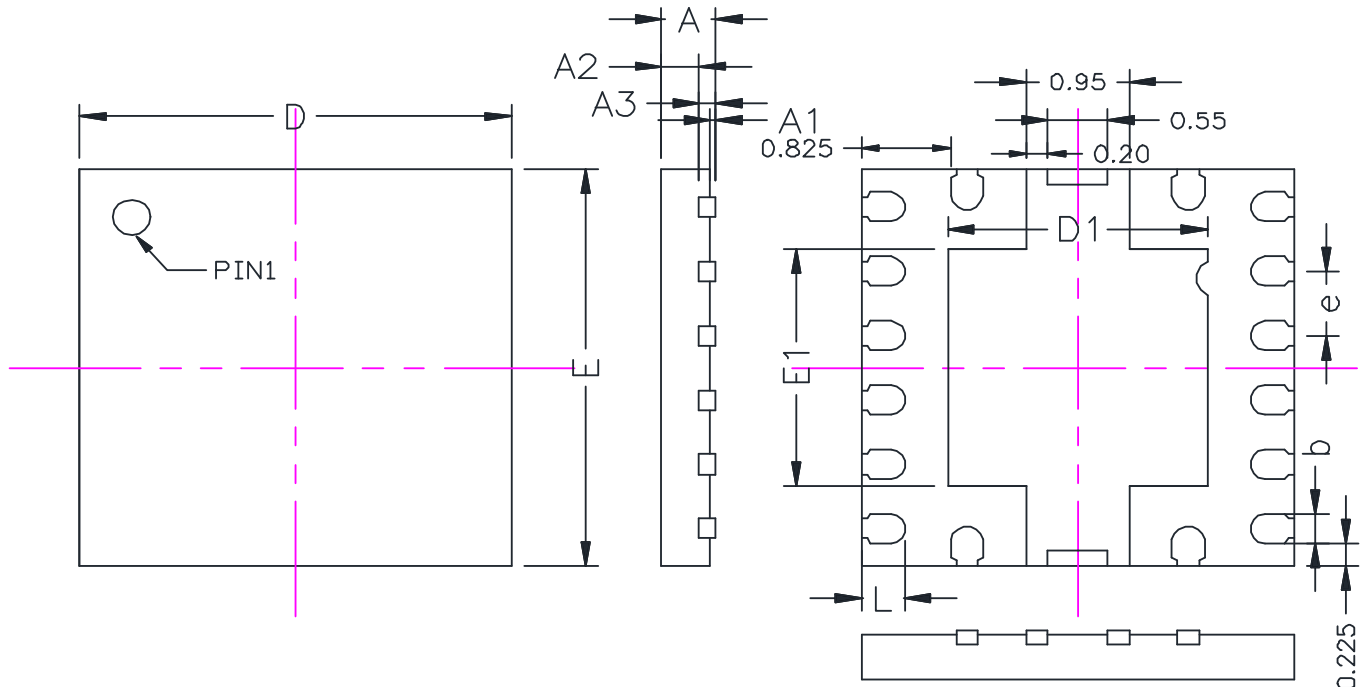

SYMBOL	MILLIMETERS		INCHES	
	Min.	Max.	Min.	Max.
A	0.40	0.50	0.016	0.020
A1	0.00	0.05	0.000	0.002
A2	0.25	0.35	0.010	0.014
A3	0.15 REF		0.006 REF	
b	0.25	0.35	0.010	0.014
D	4.00 BSC		0.157 BSC	
E	4.00 BSC		0.157 BSC	
D1	2.35	2.45	0.093	0.096
E1	2.35	2.45	0.093	0.096
L	0.35	0.45	0.014	0.018
e	0.65 BSC		0.026 BSC	

- **Marking Identification**

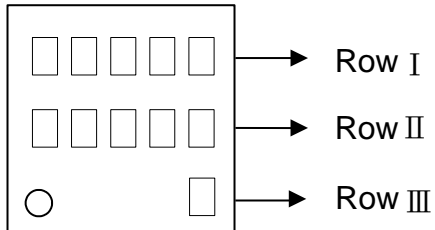

Row I
A2825

Row II
Date & Lot number

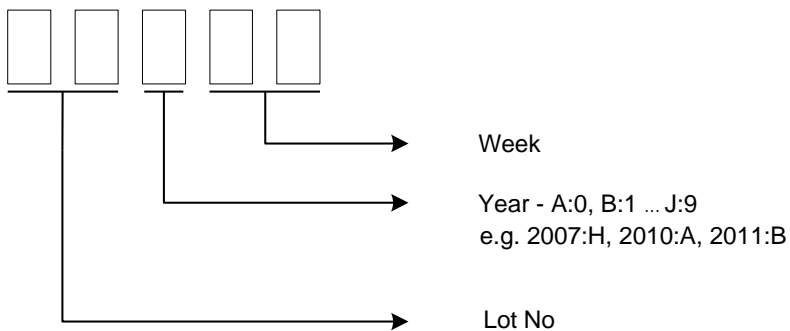

Row III
Identification code N, used to represent the last code of the AM2825N