	Cosemitech	CHX912/CHX912L
	Automotive Product Group	<small>This is advanced information on a new product now in development or undergoing evaluation. Details are subject to change without notice and Cosemitech assumes no obligation for future manufacture of this product. Contact Cosemitech for the latest status.</small>

Preliminary Datasheet 1.2

FEATURES and FUNCTIONAL DIAGRAM	PACKAGE
----------------------------------------	----------------

- AEC-Q100 qualified for CHA912 and CHA912L
- Micro-power Omnipolar-Switch Hall Sensor
- Multiple Sensitivity Options (BOP / BRP):
±33 / ±23 Gauss;
- Push-pull output ability
- Chopper stabilized design provides:
 - Superior temperature stability
 - Minimal switch point drift
 - Enhanced immunity to physical stress
- On board voltage regulator for 1.65V to 5.5V range
- Push-pull Output (1 mA current ability)
- Solid-state reliability
- Wide Operating temperature range: -40 to 150 °C
- Small package sizes TO-92S, SOT-23
- RoHS-compliant material meets directive 2011/65/EU

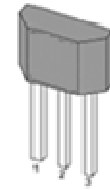
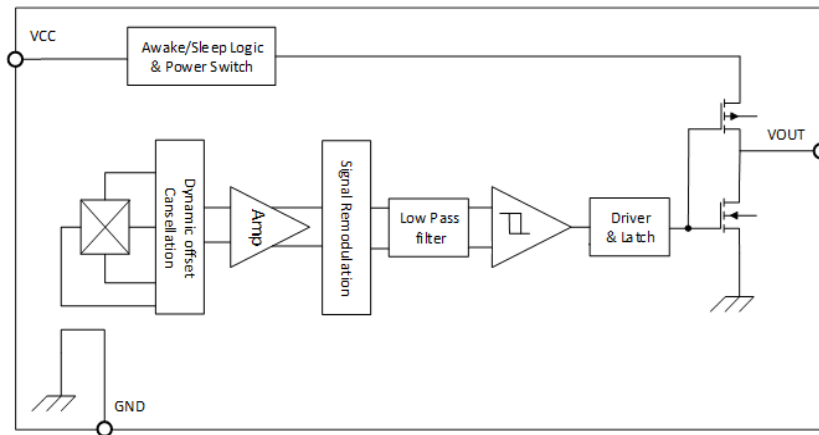

TO-92S

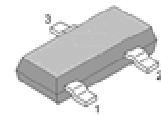

SOT-23-3L

APPLICATIONS

- Open and Close Detect for Flip/Slide Cellular Phones;
- Smart Cover or Dock Detect for Cellular Phones and Tablet PCs;
- Cover or Display Switch in Portable PCs (eg: Ultrabook);
- Digital Still, Video Cameras and Handheld Gaming Consoles;
- Door, Lids and Tray Position Switches;
- Level, Proximity and Position Switches;
- Contact-Less Switches in Home Appliances and Industrial Applications.

DESCRIPTION

The CHX912/CHX912L is a high-sensitivity extremely temperature-stable micro-power Omnipolar Hall effect switch IC with internal pull up and pull down capability. Designed for portable and battery powered consumer equipment such as cellular phones and portable PCs to office equipment, home appliances and industrial applications, the average supply current is only 4 A at 1.8V for CHX912 and 1.5uA at 1.8V for CHX912L. To support portable equipment, the CHX912/CHX912L can operate over the supply range of 1.65V to 5.5V and uses a hibernating clocking system to minimize the power consumption.

The device includes a clocking system, a Hall-voltage generator, a small-signal amplifier, a chopper stabilization, two Schmitt trigger, and an output driver controller.

The output is activated with either a north or south pole of sufficient magnetic field strength. When the magnetic flux density (B) perpendicular to the package is larger than operate point (Bop), the output will be turned on (pulled low) and held until B is lower than release point (Brp).

Two package styles provide a magnetically optimized package for most applications, SOT-23 and TO-92S. Each package type is lead (Pb) free (suffix, . T), with a 100% matte-tin-plated leadframe.

	Cosemitech	CHX912/ CHX912L
	Automotive Product Group	<small>. This is advanced information on a new product now in development or undergoing evaluation. Details are subject to change without notice and Cosemitech assumes no obligation for future manufacture of this product. Contact Cosemitech for the latest status.</small>

Preliminary Datasheet 1.2

Table of Contents

1. Product Family Members	3
2. Pin Definitions and Descriptions	3
3. Absolute Maximum Ratings	4
4. ESD Protections	4
5. Function Description	4
6. Magnetic Activation	4
7. Temperature Characterization	5
8. Parameters Specification	5
9. Application information.....	6
10. Package Information	7



Cosemitech

CHX912/CHX912L

Automotive Product Group

This is advanced information on a new product now in development or undergoing evaluation. Details are subject to change without notice and Cosemitech assumes no obligation for future manufacture of this product. Contact Cosemitech for the latest status.

Preliminary Datasheet 1.2

1. Product Family Members

Part Number	Marking ID	Description
CHA912SR	CA912	Micro-power Omnipolar-Switch, Hall-effect digital sensor IC, SOT-23-3L package, tape and reel packing (3000 units per reel)
CHA912TB	CA912	Micro-power Omnipolar-Switch, Hall-effect digital sensor IC, flat, TO-92S package, bulk packing (1000 units per bag)
CHA912LSR	A912L	Micro-power Omnipolar-Switch, Hall-effect digital sensor IC, SOT-23-3L package, tape and reel packing (3000 units per reel)
CHA912LTB	A912L	Micro-power Omnipolar-Switch, Hall-effect digital sensor IC, flat, TO-92S package, bulk packing (1000 units per bag)
CHI912SR	C912	Micro-power Omnipolar-Switch, Hall-effect digital sensor IC, SOT-23-3L package, tape and reel packing (3000 units per reel)
CHI912TB	C912	Micro-power Omnipolar-Switch, Hall-effect digital sensor IC, flat, TO-92S package, bulk packing (1000 units per bag)
CHI912LSR	912L	Micro-power Omnipolar-Switch, Hall-effect digital sensor IC, SOT-23-3L package, tape and reel packing (3000 units per reel)
CHI912LTB	912L	Micro-power Omnipolar-Switch, Hall-effect digital sensor IC, flat, TO-92S package, bulk packing (1000 units per bag)

Prefix

CHX91 2X: Micro-power Omnipolar-Switch Hall IC

CHX912X XX

Application Field

I: Industry
A: Automotive

Package

SR: SOT-23-3L, tape and reel packing
TB: TO-92S, bulk packing

Micro-power level

L: Low micro-power

2. Pin Definitions and Descriptions

SOT-23-3L (S)	TO-92S (T)	Name	Type	Function
1	1	VDD	Supply	Supply Voltage pin
2	3	OUT	Output	Push-pull Output pin
3	2	GND	Ground	Ground pin

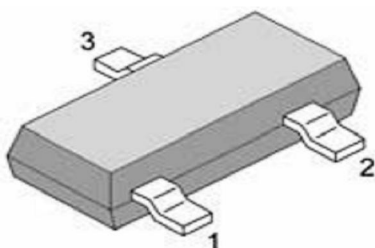

SOT-23-3L

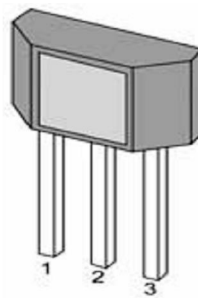

TO-92S

	Cosemitech	CHX912/ CHX912L
	Automotive Product Group	<small>. This is advanced information on a new product now in development or undergoing evaluation. Details are subject to change without notice and Cosemitech assumes no obligation for future manufacture of this product. Contact Cosemitech for the latest status.</small>

Preliminary Datasheet 1.2

3. Absolute Maximum Ratings

Parameter	Symbol	Min	Max	Units
Supply Voltage	V_{DD}	-	6	V
VDD Reverse Voltage VDD	V_{RDD}	-0.3		V
Supply Current	I_{DD}	-	3	mA
Output Voltage	V_{OUT}	-0.3	$V_{DD}+0.3$	V
Output Current	I_{OUT}	-	3	mA
Operating Ambient Temperature	T_A	-40	150	°C
Storage Temperature	T_S	-50	150	°C
Junction temperature	T_J	-50	165	°C
Magnetic Flux	B	No Limit		Gauss

Note: Exceeding the absolute maximum ratings may cause permanent damage. Exposure to absolute-maximum- rated conditions for extended periods may affect device reliability.

4. ESD Protections

Parameter	Value	Unit
All pins ¹⁾	+/-8000	V
All pins ²⁾	+/-400	V
All pins ³⁾	+/-1500	V

- 1) HBM (Human Body Mode) according to AEC-Q100-002
- 2) MM (Machine Mode) according to AEC-Q100-003
- 3) CDM (charged device mode) according to AEC-Q100-011

5. Function Description

The CHX912/CHX912L exhibits Micro-power digital Omnipolar switching characteristics. Therefore, it requires only south poles or north poles to operate properly.

When the applied magnetic flux density exceeds the BOP threshold, the chip push-pull output goes low. The output stays low until the field decreases to less than BRP, and then the output goes to high.

A magnetic hysteresis BHYST keeps BOP and BRP separated by a minimal value. This hysteresis prevents output oscillation near the switching point.

6. Magnetic Activation

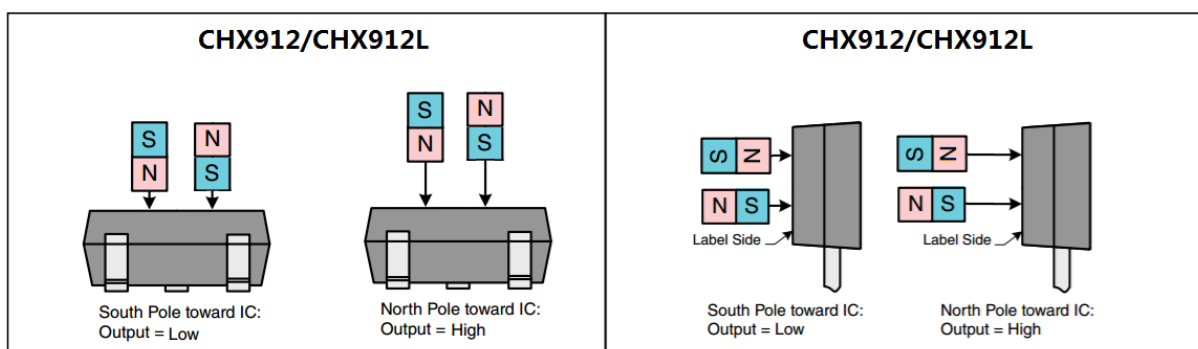



Cosemitech

CHX912/CHX912L

Automotive Product Group

This is advanced information on a new product now in development or undergoing evaluation. Details are subject to change without notice and Cosemitech assumes no obligation for future manufacture of this product. Contact Cosemitech for the latest status.

Preliminary Datasheet 1.2

7. Temperature Characteristics

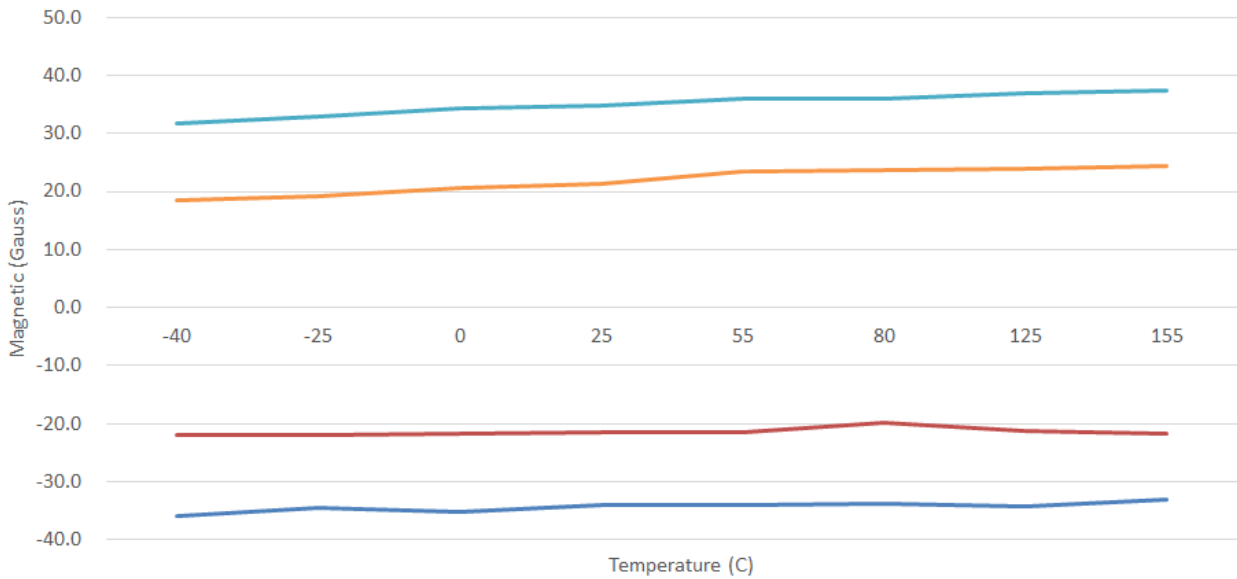

8. Parameters Specification (VCC=3V supply, TA= -40 °C to 150 °C except where otherwise specified.)

Symbol	Characteristic	Test Conditions	Min.	Typ.	Max.	Unit
V _{CC}	Supply Voltage	Operating, T _J < 165°C	1.65		5.5	V
I _{CC(awake)}	CHX912 Supply Current	During awake period, TA = 25°C, VCC=3.3V	.	1.1	1.6	mA
	CHX912L Supply Current		.	1.1	1.6	mA
I _{CC(sleep)}	CHX912 Supply Current	During sleep period, TA = 25°C, VCC=3.3V	.	2.5	.	uA
	CHX912L Supply Current		.	1.5	.	uA
I _{CC(avg)}	CHX912 Average supply current	TA = 25°C, VDD = 1.8V		4		uA
		TA = 25°C, VDD = 3.3V		5		uA
	CHX912L Average supply current	TA = 25°C, VDD = 1.8V		1.5		uA
		TA = 25°C, VDD = 3.3V		2		uA
V _{OL}	Output low voltage(on)	I _{OUT} = 1 mA	.	0.1	0.2	V
V _{OH}	Output high voltage(off)	I _{OUT} = -1mA	V _{CC} -0.2	V _{CC} -0.1	.	V
T _{awake}	CHX912 Awake time	(note4)	.	40	60	us
	CHX912L Awake time	(note4)	.	40	60	us
T _{period}	CHX912 Period	(note4)	.	30	50	ms
	CHX912L Period	(note4)	.	100	200	mS
D.C.	Duty cycle	.	.	0.13	.	%
f _c	Chopping Frequency		.	500	.	kHz
I _{OFF}	Output Leakage Current	V _{OUT} = 5.5 V; Switch state = Off	.	.	1	A
Bop	Operate point	VDD = 1.6V to 5.5V TA = -40°C to 150°C	±23	±33	±48	Gauss

	Cosemitech	CHX912/ CHX912L
	Automotive Product Group	<small>. This is advanced information on a new product now in development or undergoing evaluation. Details are subject to change without notice and Cosemitech assumes no obligation for future manufacture of this product. Contact Cosemitech for the latest status.</small>

Preliminary Datasheet 1.2

Brp	Release point	VDD = 1.6V to 5.5V TA = -40°C to 150°C	±13	±23	±38	Gauss
Hys	Hysteresis	VDD = 1.6V to 5.5V TA = -40°C to 150°C	.	10	.	Gauss

- 1G (gauss) = 0.1 mT (millitesla).
- Measured from 10% to 90% of the steady state output.
- When power is initially turned on, the operating VCC (1.6V to 5.5V) must be applied to guaranteed the output sampling. The output state is valid after the second operating cycle (typical 100ms).

NOTICE

The magnetic field strength (Gauss) required to cause the switch to change state (operate and release) will be as specified in the magnetic characteristics. To test the switch against the specified magnetic characteristics, the switch must be placed in a uniform magnetic field.

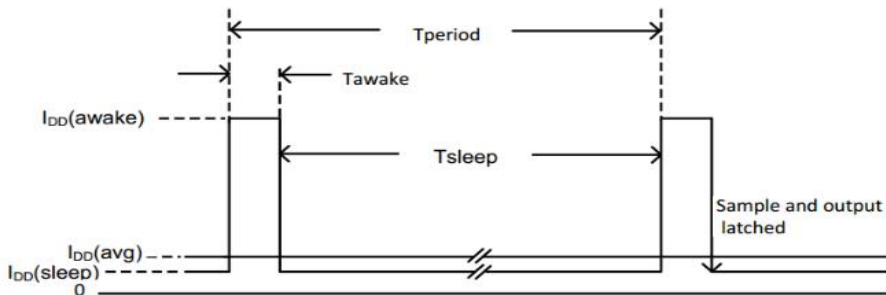

9. Application Information

9.1 Typical Application

It is recommended that an external capacitor C_{IN} is connected to the supply. This can reduce the noise injected into the device. Normal 0.1uF is suggested.

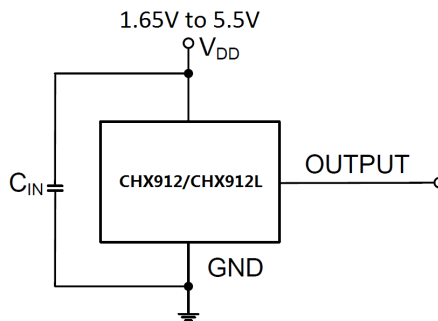

Typical Application Circuit

9.2 Device Output

If the device is powered on with a magnetic field strength between BRP and BOP, then the device output is indeterminate and can either be high or Low. If the field strength is greater than BOP, then the output is pulled low. If the field strength is less than BRP, then the output is pulled high.

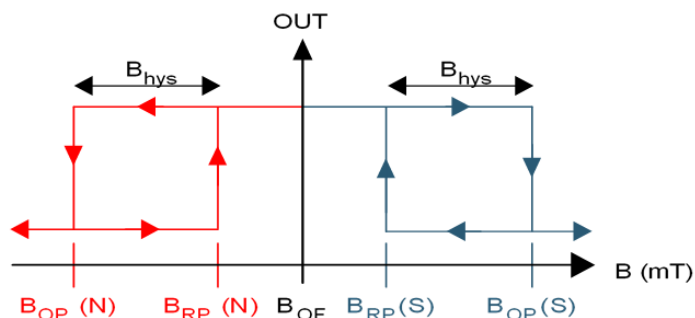

10. Package Information:

**PACKAGE DESIGNATOR
TO-92S**

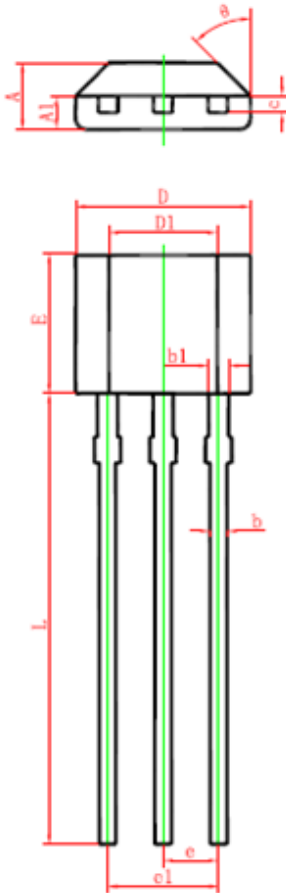

Symbol	Dimensions In Millimeters		Dimensions In Inches	
	Min.	Max.	Min.	Max.
A	1.420	1.620	0.056	0.064
A1	0.660	0.860	0.026	0.034
b	0.350	0.480	0.014	0.019
b1	0.400	0.550	0.016	0.022
c	0.360	0.510	0.014	0.020
D	3.900	4.100	0.154	0.161
D1	2.280	2.680	0.090	0.106
E	3.050	3.250	0.120	0.128
e	1.270 TYP.		0.050 TYP.	
e1	2.440	2.640	0.096	0.104
L	15.100	15.500	0.594	0.610
θ	45° TYP.		45° TYP.	

PACKAGE DESIGNATOR
SOT-23-3L

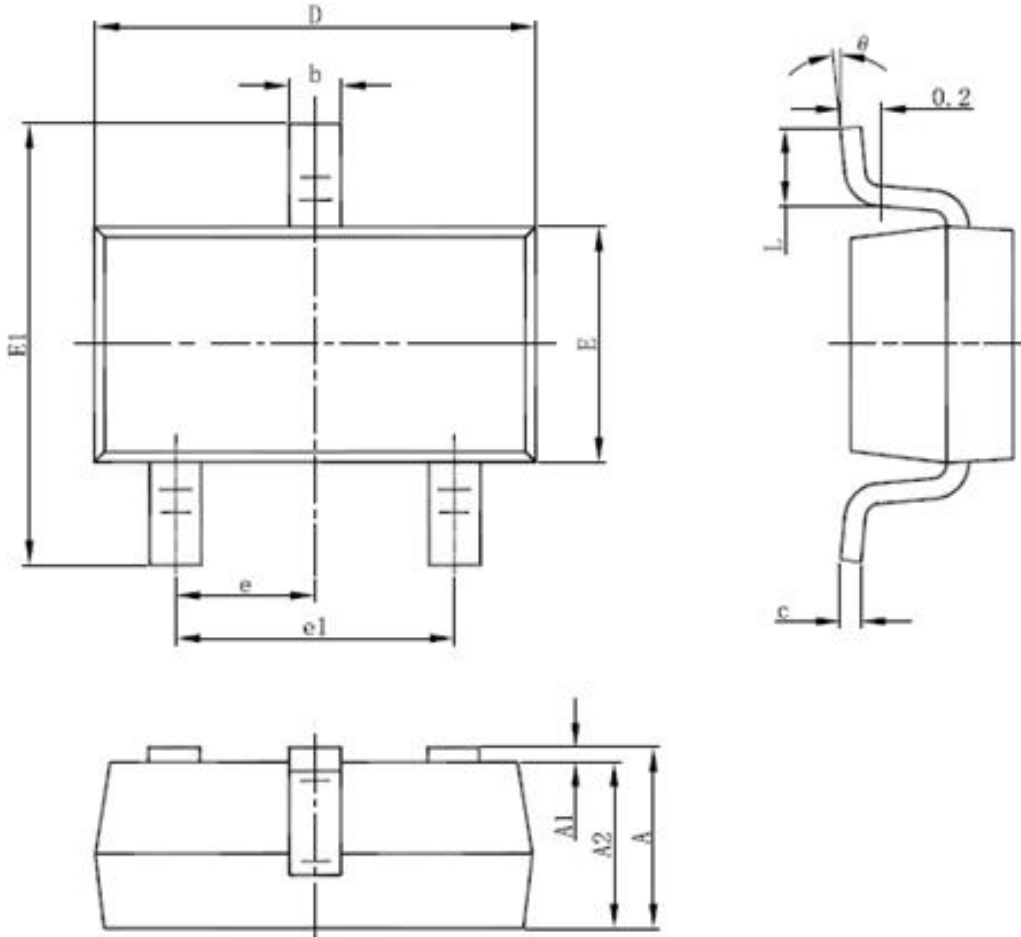

Symbol	Dimensions In Millimeters		Dimensions In Inches	
	Min	Max	Min	Max
A	1.050	1.250	0.041	0.049
A1	0.000	0.100	0.000	0.004
A2	1.050	1.150	0.041	0.045
b	0.300	0.500	0.012	0.020
c	0.100	0.200	0.004	0.008
D	2.820	3.020	0.111	0.119
E	1.500	1.700	0.059	0.067
E1	2.650	2.950	0.104	0.116
e	0.950(BSC)		0.037(BSC)	
e1	1.800	2.000	0.071	0.079
L	0.300	0.600	0.012	0.024
θ	0°	8°	0°	8°

	Cosemitech	CHX912/CHX912L
	Automotive Product Group	<small>This is advanced information on a new product now in development or undergoing evaluation. Details are subject to change without notice and Cosemitech assumes no obligation for future manufacture of this product. Contact Cosemitech for the latest status.</small>

Preliminary Datasheet 1.2

Information furnished is believed to be accurate and reliable. However, Cosemitech assumes no responsibility for the consequences of use of such information nor for any infringement of patents or other rights of third parties which may result from its use. No license is granted by implication or otherwise under any patent or patent rights of Cosemitech. Specification mentioned in this publication are subject to change without notice. This publication supersedes and replaces all information previously supplied. Cosemitech products are not authorized for use as critical components in life support devices or systems without express written approval of Cosemitech.

The Cosemitech logo is a registered trademark of Cosemitech