

# Single Phase Full-Wave Fan Motor Driver

## AM1961

The AM1961 is a single-phase bipolar variable speed fan motor driver IC. It contains several protect functions for safe consideration; The AM1961 is particularly well suited for the computer cooling system. Halogen – free package is selectable (Please refer to last page Marking Identification).

### ● Application

CPU fan, power supply cooling and consumer products.

### ● Features

- |  |                                       |
|--|---------------------------------------|
| 1) Single-phase full-wave driver.(1A,16V)  | 4) Over-Current protection.           |
| 2) Variable speed control with thermistor input or PWM drive with additional components. | 5) Lock-Protection and Auto-Recovery. |
| 3) Minimum speed setting pin.  | 6) FG / RD indication.                |
|  | 7) Hall bias built-in.                |
|  | 8) Thermal shutdown function.         |

### ● Absolute Maximum Ratings (Ta=25°C)

Parameter	Symbol	Limits	Unit
VCC Max supply voltage	VCCmax	18	V
OUT Pin Max output Current	I_OUTmax	1	A
OUT Pin Output withstand Voltage	V_OUTmax	18	V
HB Max output Current	IHBmax	10	mA
VTH pin input Voltage	VTHmax	7	V
RD/FG Pin Output withstand Voltage	VRDFGmax	18	V
RD/FG Maximum output current	IRDFGmax	10	mA
6VREG Maximum output current	I_6VREGmax	10	mA
Power dissipation	Pd	*1.1	W
Junction Temperature Maximum	Tjmax	175	°C
Operating temperature	Topr	-30°C~+95°C	°C
Storage Temperature	Tstg	** -55°C~+150°C	°C

\*When mounted on a 114.3mm×76.1mm×1.6mm single layer board.

\*Reduced by 8.9mW for each increase in Ta of 1°C over 25°C.

\*\*Should not exceed Pd or ASO and Tj=150°C values

### ● Recommended Operating Ranges at Ta=25°C

Parameter	Symbol	Conditions	Limits	Unit
VCC Supply voltage	VCC		3.5~16	V
VTH input voltage range	VTH		0~6VREG	V
HALL input common mode range	VICM		0.2~3	V

● **ELECTRICAL CHARACTERISTICS**

(Test conditions  $V_{CC}=12V$ ,  $T=25^{\circ}C$  unless otherwise stated)

Parameter	Symbol	Limit			Unit	Conditions	P.S
		Min.	Typ.	Max.			
Circuits current 1	ICC1	12	18	24	mA	Drive mode	
Circuits current 2	ICC2	10	16	20	mA	Lock Protection	
6VREG Voltage	6VREG	5.8	6.0	6.2	V	I6VREG=5mA	
HB Voltage	VHB	1.10	1.25	1.40	V	IHB=5mA	
CPWM pin H-level voltage	VCRH	3.45	3.60	3.75	V		
CPWM pin L-level voltage	VCRL	1.95	2.05	2.15	V		
CPWM pin frequency	FOSC	18	25	32	KHz	C=100PF	
CT pin H-level voltage	VCTH	3.45	3.60	3.75	V		
CT pin L-level voltage	VCTL	1.55	1.7	1.85	V		
CT pin charge current	ICT1	1.5	2.0	2.5	$\mu A$		
CT pin discharge current	ICT2	0.15	0.2	0.25	$\mu A$		
CT pin charge/discharge ratio	RCT	9.5	11	12.5		ICT1/ICT2	
Output low saturation voltage	VOL		0.2	0.3	V	IO=200mA	
Output high saturation voltage	VOH		0.9	1.1	V	IO=200mA	
Hall input sensitivity	VHN		$\pm 10$	$\pm 20$	mV	IN+ and IN- voltage difference	
RD/FG pin output low voltage	VRDL/FGL		0.2	0.3	V	IRD/FG=5mA	
RD/FG pin leakage current	IRDL/FGL			30	$\mu A$	VRD/FG=18V	
Thermal Shutdown	TSD		(*)175		$^{\circ}C$		(**)Tj
Thermal Shutdown Hysteresis	TSDH	10	*20	30	$^{\circ}C$		**Tc
Over current protection	IOCP		*1.5		A		

\* Design guarantee: Indicates a design target value. These parameters are not tested in the independent IC.

(\*\*): Tj (Junction temperature)

● Truth table

VTH	IN-	IN+	CPWM	CT	OUT1	OUT2	FG	RD	Mode	
LOW (OPEN)	H	L	H	L	H	L	L	ON	During rotation-drive(PWM off)	
	L	H			L	H	OFF			OFF
High	H	L	L		L	OFF	L		L	During rotation-regeneration(PWM on)
	L	H				L	OFF		OFF	
-	H	L	-	H	L	OFF	L	OFF	Lock Protection	
-	L	H			OFF	L	OFF			

CPWM: HIGH is the state where CPWM>VTH, and LOW is the state where CPWM<VTH

Open: The AM1961 operates in full-speed mode when the thermistor is removed.

● Block diagram

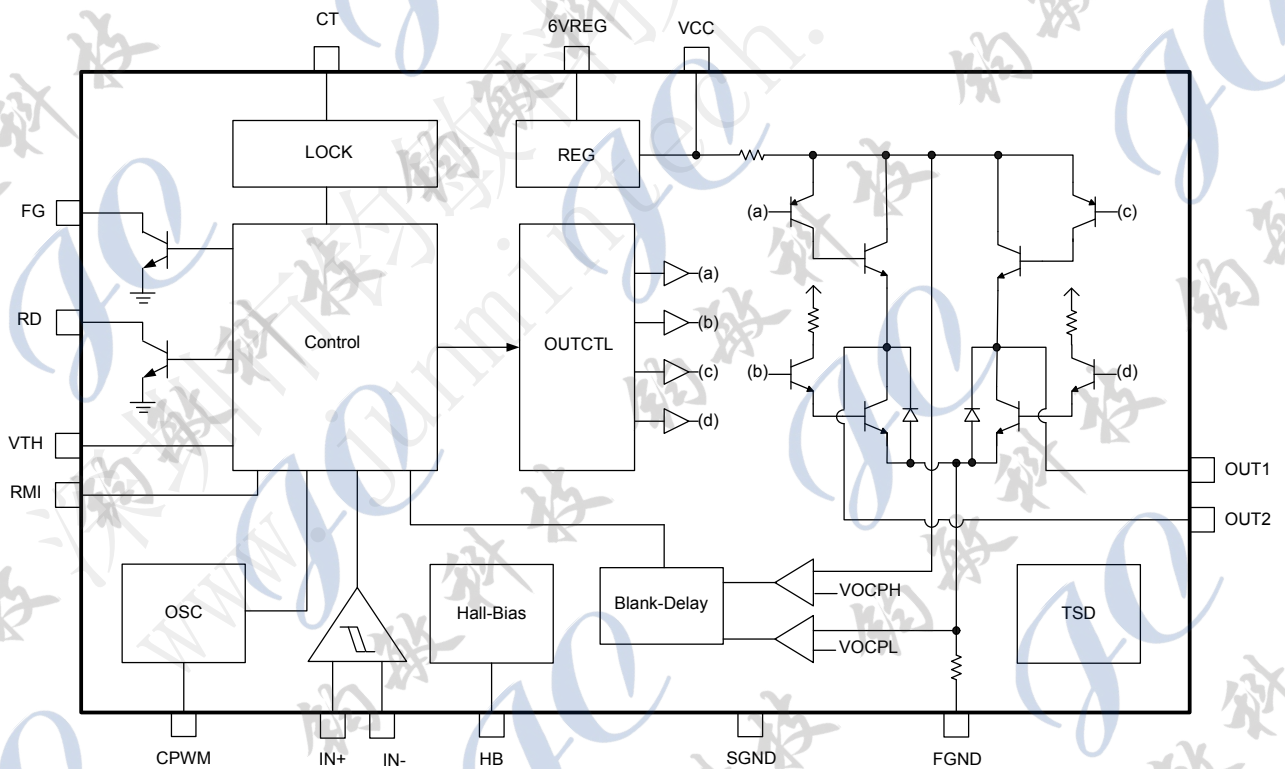

● Pin configuration

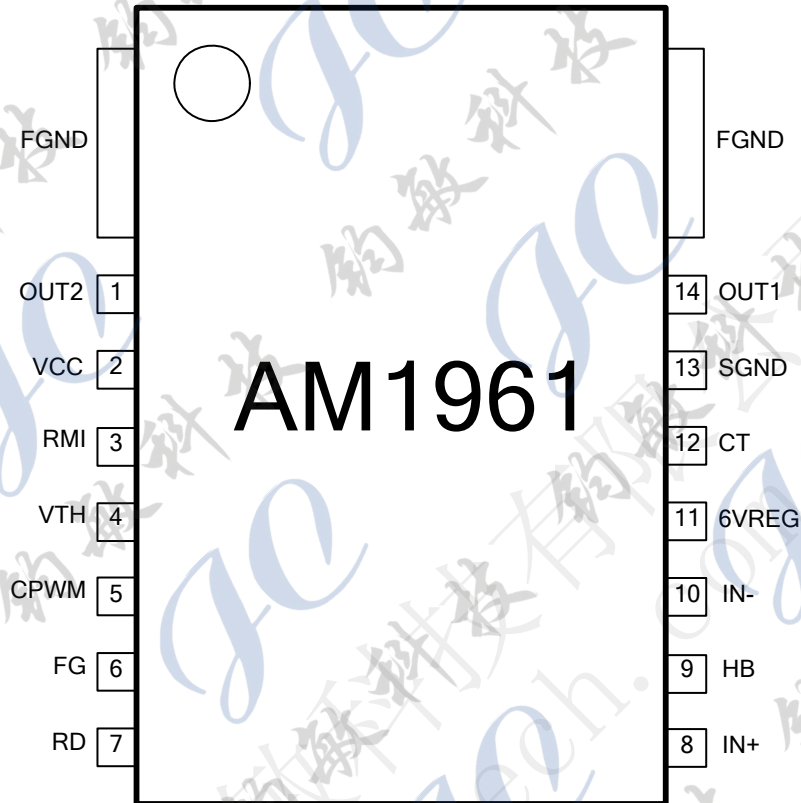

● Pin description

PIN No	Pin Name	Function
1	OUT2	Drive output 2.
2	VCC	Power supply
3	RMI	Motor minimum speed setup pin
4	VTH	Motor speed control pin
5	CPWM	Oscillation pin with external capacitor.
6	FG	Frequency generator.
7	RD	Ready detector.
8	IN+	Hall sensor positive input pin.
9	HB	Hall sensor bias pin.
10	IN-	Hall sensor negative input pin
11	6VREG	6V regulator.
12	CT	Lock-Protection with external capacitor.
13	SGND	Ground for analog circuits.
14	OUT1	Drive output 1.

Notes) FGND: Power ground for driver circuits. Please connect with SGND as short as possible.

● Typical application circuit

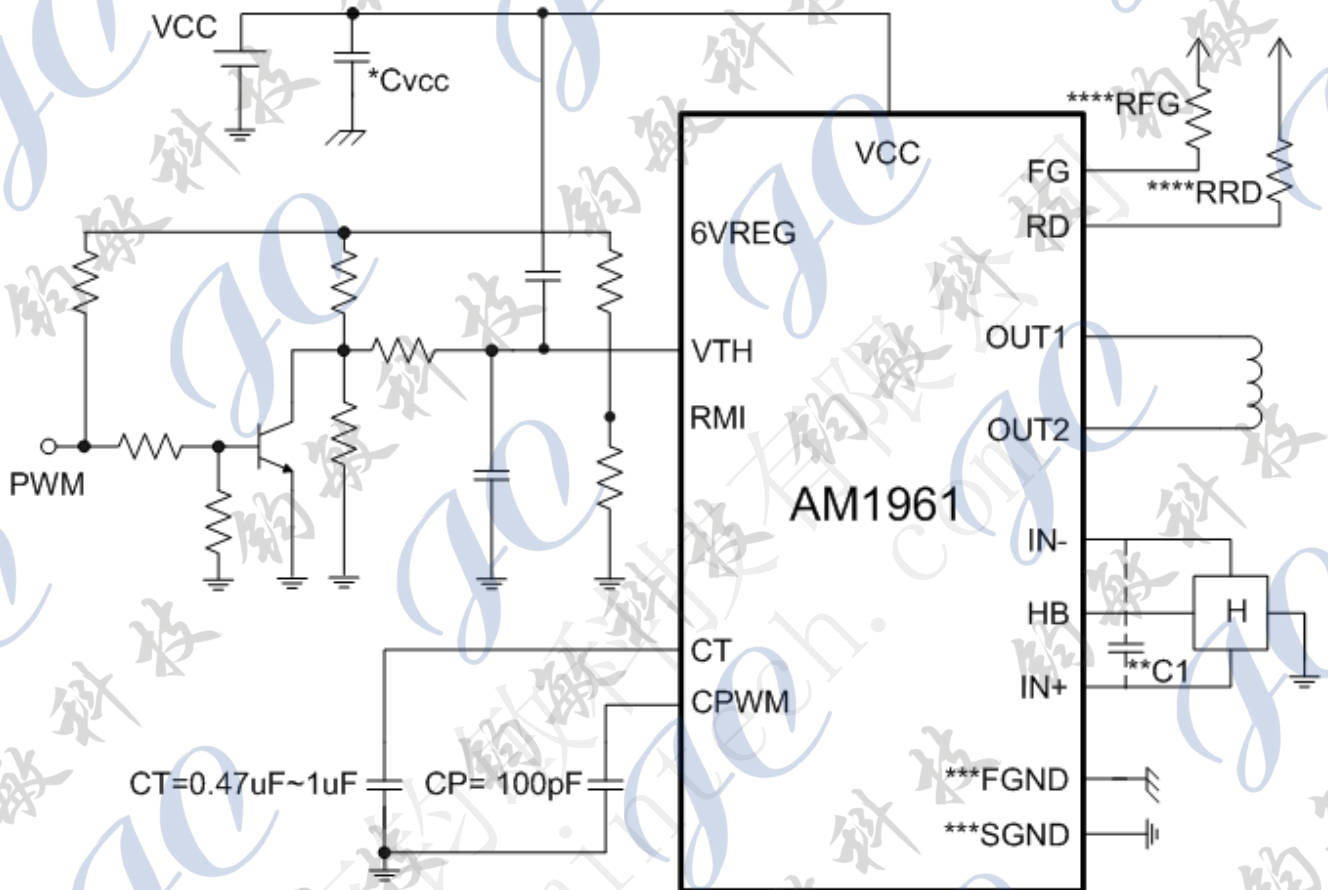

Note:

\* Cvc Capacitor is a power stabilizing capacitor for PWM driver and kick-back absorption and has the capacitance of 1uF or more. A large capacitor must be used when the coil inductance is large or when the coil resistor is low. Connect Cvc with the thick and shortest possible pattern between VCC and FGND.

\*\* When wiring from the hall element output to IC hall input is long. Noise may be loaded on wiring in this case, place a capacitor like C1 in above graphic.

\*\*\* FGND is connected to the motor power system while SGND is connected to the control circuit power system. Wiring is made separately for FGND and SGND. And the external parts of each control system are connected to SGND.

\*\*\*\* For EOS consideration, suggest to adding a small resistor (50Ω~100Ω) on FG pin and RD pin, when that is used.

● Power dissipation curve:

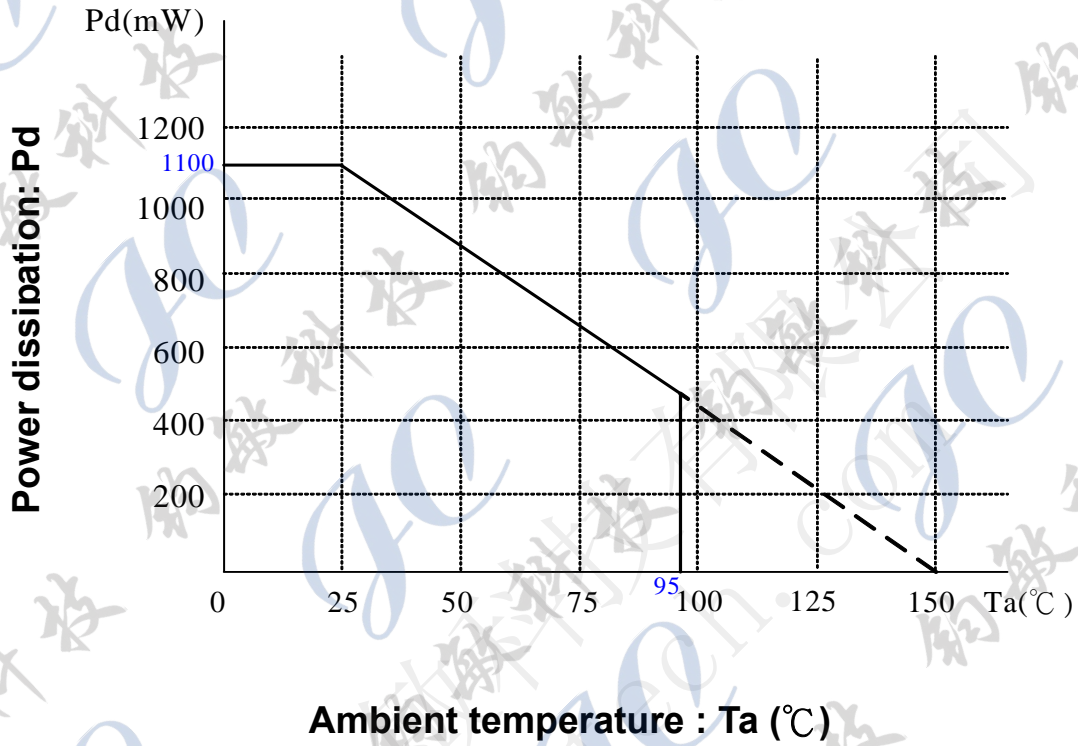

\*114.3mm×76.1mm×1.6mm single layer board.

De-rating is done at 8.9 mW/°C for operating above  $T_a=25^\circ\text{C}$

$\Theta_{Ja}=111.4^\circ\text{C/W}$ ,  $\Theta_{Jc}=27^\circ\text{C/W}$ ,  $T_j \text{ max}=175^\circ\text{C}$ ,  $P_d \text{ max} 1100\text{mw}$ .

● **Function description:**

- Speed Control :

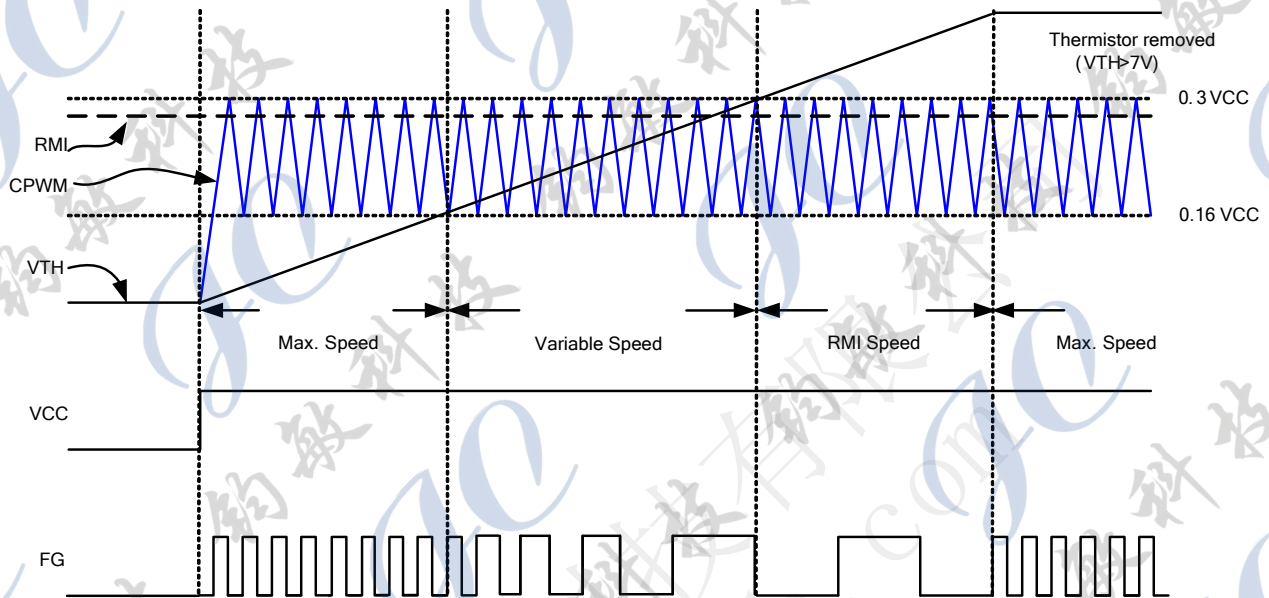

1. Minimum speed mode

When VTH increasing to higher voltage than CPWM\_H ( $0.28 \cdot V_{CC}$ ), the motor operate at the lowest speed, which is set with the RMI pin.

2. Variable speed mode

The PWM signal is controlled by comparing the PWM and VTH signal, when VTH become lower, then the coil current increases because of the PWM Output-On duty increases. And the motor is accelerating the speed.

3. Max speed mode

When AM1961 work above certain setting ( $V_{TH} < 0.16V_{CC}$ ), the device will operate in full speed mode.

4. Thermistor removed mode

If use the thermistor application when thermistor is removed, the VTH voltage will rise to high. When VTH over  $6V_{REG} + 0.7V$ , the motor will run at full speed.

### - LOCK-Protection

When the rotor is locked, input signal of hall amplifier is fixed and thus the internal signal EDGE pulse is not observed. A capacitor (CT) connected to CT pin is continually charged by a internal current (ICT1) to VCTH resulting from no EDGE pulse. When the voltage of CT Pin reached the VCTH, Low side output TR is turn off to protect motor during T-LockOn, and the RD Pin is pulled to high level. CT Pin start to discharge by another internal current ICT2 during T-LockOn. When the voltage of CT Pin reached the VCTL, At the time, the voltage of CT Pin ramp up again and one of two outputs is turned on depending on locked rotor position. The charge and discharge period will be repeated until locked condition is removed. The overall timing chart is shown as below. The Auto De-lock time (T-LockOff) and Lock- Protection time(T-LockOn) are set by external capacitor, CT. Each value can calculate by following formula:

$$T\text{-LockOn} = [CT * (VCTH-VCTL)]/ICT2$$

$$T\text{-LockOff} = [CT * (VCTH-VCTL)]/ICT1$$

### - Timing chart of LOCK state

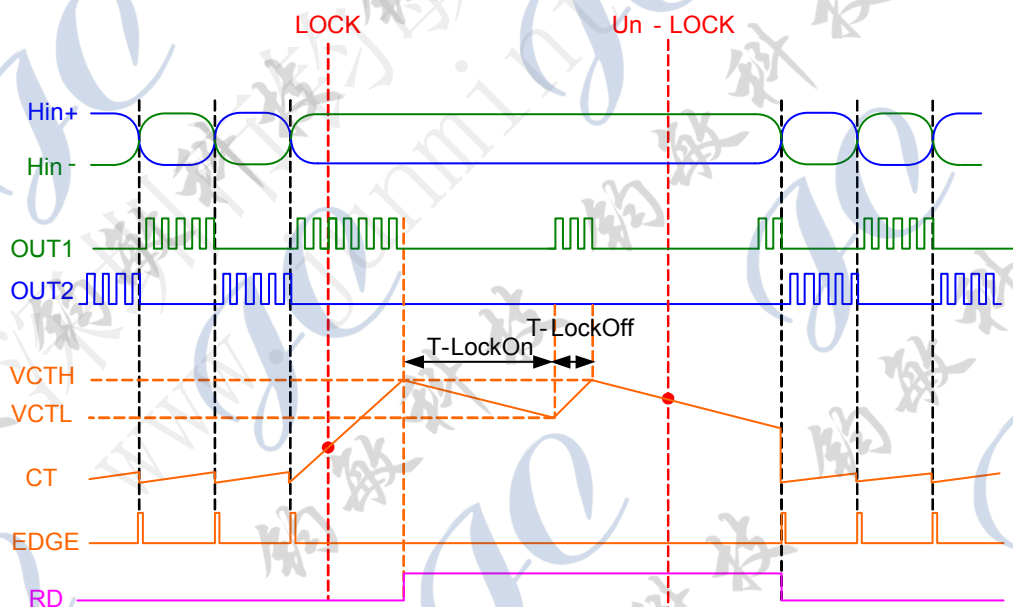



● Packaging outline --- HTSSOP14L

Unit : mm

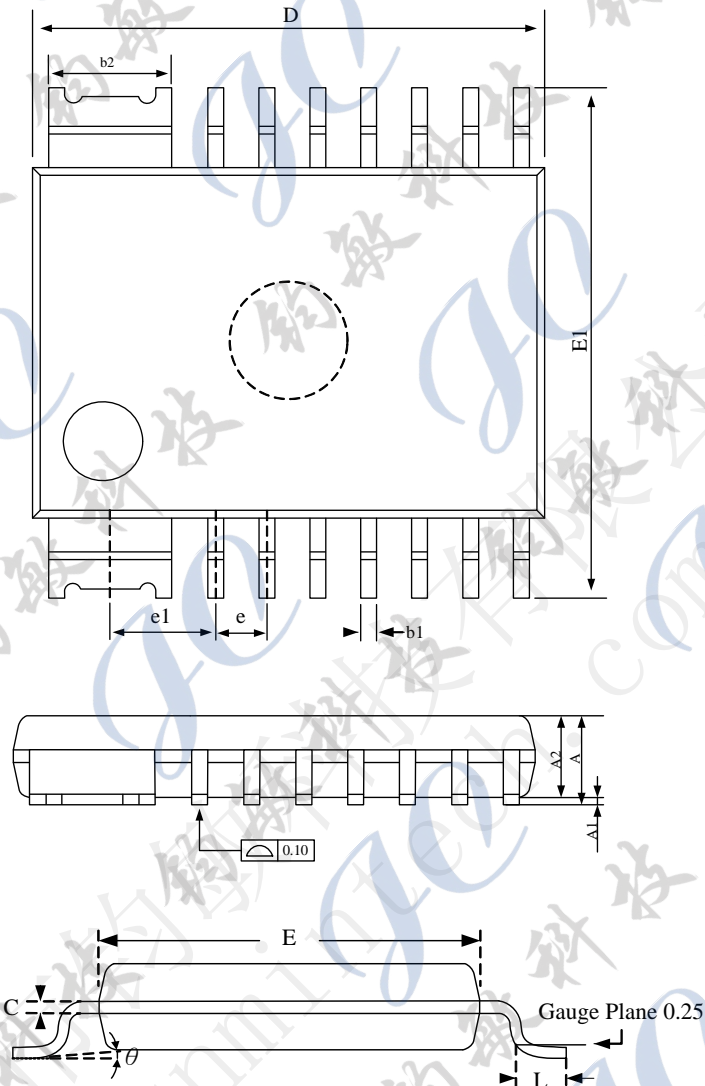

SYMBOL	Millimeters		Inches	
	Min.	Max.	Min.	Max.
A	-	1.20	-	0.047
A1	0.05	0.20	0.002	0.008
A2	0.90	1.05	0.035	0.041
b1	0.20	0.24	0.008	0.009
b2	1.47	1.57	0.058	0.062
C	0.10	0.15	0.004	0.006
D	6.35	6.73	0.250	0.265
E	4.30	4.50	0.169	0.177
E1	6.20	6.60	0.244	0.260
e	0.65BSC		0.026BSC	
e1	1.30BSC		0.051BSC	
L	0.45	0.75	0.018	0.030
θ	0°	8°	0°	8°

● **Condition of Soldering**

**1).Manual Soldering**

Time / Temperature  $\leq$  3 sec /  $400 \pm 10^\circ\text{C}$  (2 Times)

Test Results : 0 fail/ 22 tested

Manual Soldering count : 2 Times

**2).Re-flow Soldering (follow IPC/JEDEC J-STD-020D)**

Classification Reflow Profile

Profile Feature	Pb-Free Assembly
Average ramp-up rate ( $T_L$ to $T_P$ )	$3^\circ\text{C}/\text{second max.}$
Preheat	
- Temperature Min ( $T_{s \text{ min}}$ )	$150^\circ\text{C}$
- Temperature Max ( $T_{s \text{ max}}$ )	$200^\circ\text{C}$
- Time (min to max) ( $t_s$ )	60-180 seconds
$T_{s \text{ max}}$ to $T_L$	
- Temperature Min ( $T_{s \text{ min}}$ )	$3^\circ\text{C}/\text{second max.}$
Time maintained above:	
- Temperature ( $T_L$ )	$217^\circ\text{C}$
- Time ( $t_L$ )	60-150 seconds
Peak Temperature ( $T_P$ )	$260 \pm 0/-5^\circ\text{C}$
Time with $5^\circ\text{C}$ of actual Peak	20-40 seconds
- Temperature ( $t_p$ )	
Ramp-down Rate	$6^\circ\text{C}/\text{second max.}$
Time $25^\circ\text{C}$ to Peak Temperature	8 minutes max.

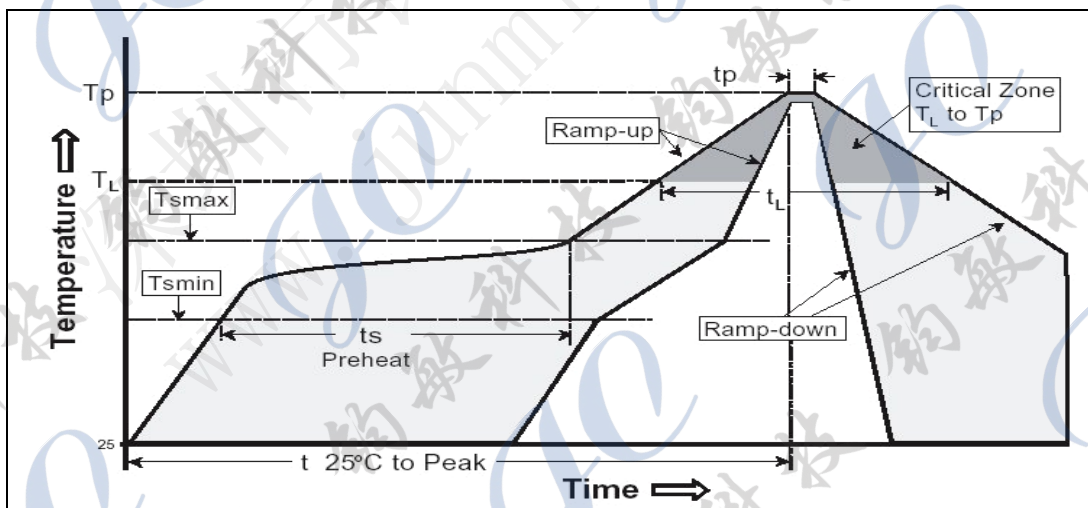

- Test Results : 0 fail/ 32 tested
- Reflow count : 3 cycles

## Marking Identification

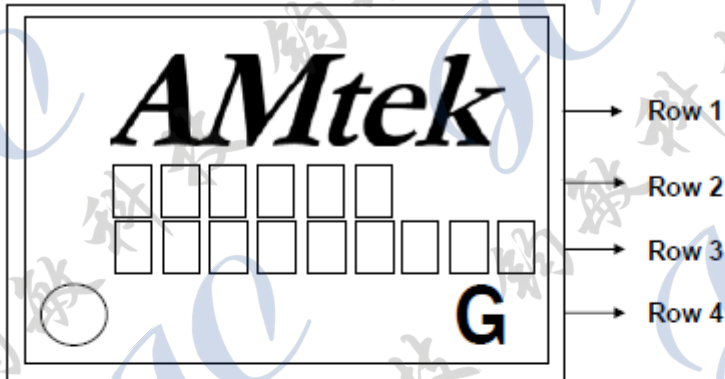

Row 1: AMtek

Row 2: Part number

Row 3: 

--	--	--	--	--	--	--	--

Week (WW) (mean : 01~52)

Year : A~J (mean : 0~9)

Lot no

Row 4: G = Halogen Free