

	Cosemitech	CHA44X/CH44X
	Automotive Product Group	<small>This is advanced information on a new product now in development or undergoing evaluation. Details are subject to change without notice and Cosemitech assumes no obligation for future manufacture of this product. Contact Cosemitech for the latest status.</small>

Preliminary Datasheet 2.1

FEATURES and FUNCTIONAL DIAGRAM

- AEC-Q100 automotive qualified for CHA44X
- Digital Bipolar-Latch Hall Sensor
- Multiple Sensitivity Options (BOP / BRP):
+15 / -15 Gauss; +30 / -30 Gauss; +45 / -45 Gauss; +120 / -120 Gauss;
- Chopper stabilization for stable operate points throughout operating temperature range
- On board voltage regulator for 2.5V to 22V range
- Resistant to physical stress
- Output short-circuit protection
- Operation from unregulated supply
- Reverse-battery and freewheeling protection
- Solid-state reliability
- Wide Operating temperature range: -40 to 150 °C
- Small package sizes TO-92S, SOT-23 and SOT-89
- RoHS-compliant material meets directive 2011/65/EU

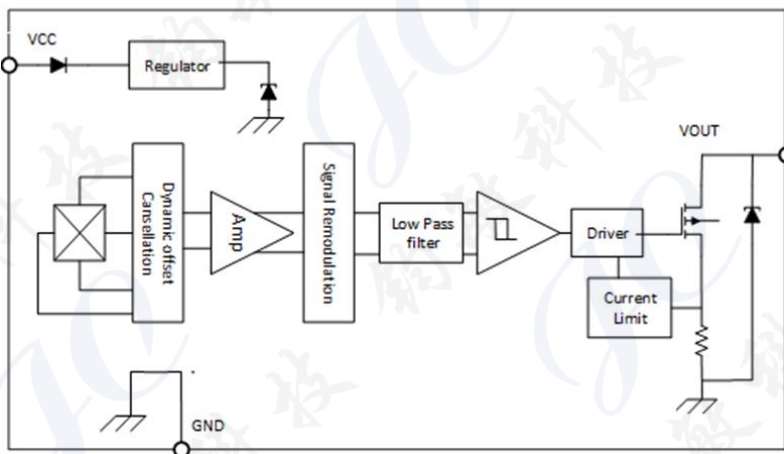

PACKAGE

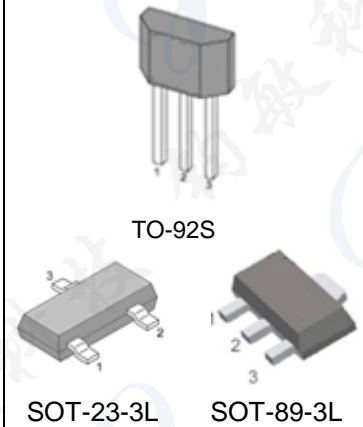

APPLICATIONS

- Speed and RPM sensing
- Tachometer, counter pickup
- Flow-rate sensing
- Brushless dc (direct current) motor commutation
- Motor and fan control
- Robotics control

DESCRIPTION

The CHA44X/CH44X Hall-effect sensor is extremely temperature-stable and stress-resistant sensor ICs, especially suited for operation over extended temperature ranges from -40°C to 150°C. Superior high temperature performance is possible through dynamic offset cancellation, which reduces the residual offset voltage normally caused by device over-molding, temperature dependencies, and thermal stress.

The device includes a voltage regulator, Hall-voltage generator, small-signal amplifier, chopper stabilization, Schmitt trigger, and a short circuit protected open-drain output to sink up to 25 mA.

An on-board regulator permits operation with supply voltages of 2.5 to 22 V. The advantage of operating down to 2.5V is that the device can be used in 2.5V applications or with additional external resistance in series with the supply pin for greater protection against high-voltage transient events.

The CHA44X/CH44X series is latch Hall switch. For the latch mode, there are also invert polarity devices. Normally a south pole of sufficient strength turns on the output; However, for invert polarity devices, a north pole of sufficient strength turns on the output.

The CHA44X/CH44X also integrated internal clamps against supply/output transients; output short circuits protection; reverse battery conditions.

Three package styles provide a magnetically optimized package for most applications, SOT-23, TO-92S and SOT-89. Each package type is lead (Pb) free (suffix, -T), with a 100% matte-tin-plated lead-frame.



Cosemitech

CHA44X/CH44X

Automotive Product Group

. This is advanced information on a new product now in development or undergoing evaluation. Details are subject to change without notice and Cosemitech assumes no obligation for future manufacture of this product. Contact Cosemitech for the latest status.

Preliminary Datasheet 2.1

Table of Contents

1. Product Family Members.....	3
2. Pin Definitions and Descriptions	3
3. Absolute Maximum Ratings.....	3
4. ESD Protections	5
5. Function Description	5
6. Definition of Switching Function	5
7. Temperature Characterization	5
8. Parameters Specification.....	6
9. Application information	7
10. Test Condition	7
11. Package Information	8

	Cosemitech	CHA44X/CH44X
	Automotive Product Group	<small>This is advanced information on a new product now in development or undergoing evaluation. Details are subject to change without notice and Cosemitech assumes no obligation for future manufacture of this product. Contact Cosemitech for the latest status.</small>

Preliminary Datasheet 2.1

1. Product Family Members

1.1 CHA44X is automotive class product family

Part Number	Marking ID	Description
CHA441SR	CA441	Bipolar latching, Hall-effect digital sensor IC, SOT-23-3L package, tape and reel packing (3000 units per reel)
CHA441TB	CA441	Bipolar latching, Hall-effect digital sensor IC, flat, TO-92S package, bulk packing (1000 units per bag)
CHA441ER	CA441	Bipolar latching, Hall-effect digital sensor IC, SOT-89-3L package, tape and reel packing (1000 units per reel)
CHA442SR	CA442	Bipolar latching, Hall-effect digital sensor IC, SOT-23-3L package, tape and reel packing (3000 units per reel)
CHA442TB	CA442	Bipolar latching, Hall-effect digital sensor IC, flat, TO-92S package, bulk packing (1000 units per bag)
CHA442ER	CA442	Bipolar latching, Hall-effect digital sensor IC, SOT-89-3L package, tape and reel packing (1000 units per reel)
CHA443SR	CA443	Bipolar latching, Hall-effect digital sensor IC, SOT-23-3L package, tape and reel packing (3000 units per reel)
CHA443TB	CA443	Bipolar latching, Hall-effect digital sensor IC, flat, TO-92S package, bulk packing (1000 units per bag)
CHA443ER	CA443	Bipolar latching, Hall-effect digital sensor IC, SOT-89-3L package, tape and reel packing (1000 units per reel)
CHA444SR	CA444	Bipolar latching, Hall-effect digital sensor IC, SOT-23-3L package, tape and reel packing (3000 units per reel)
CHA444TB	CA444	Bipolar latching, Hall-effect digital sensor IC, flat, TO-92S package, bulk packing (1000 units per bag)
CHA444ER	CA444	Bipolar latching, Hall-effect digital sensor IC, SOT-89-3L package, tape and reel packing (1000 units per reel)
CHA441NSR	A441N	Bipolar latching, Hall-effect digital sensor IC, SOT-23-3L package, tape and reel packing (3000 units per reel)
CHA441NTB	A441N	Bipolar latching, Hall-effect digital sensor IC, flat, TO-92S package, bulk packing (1000 units per bag)
CHA441NER	A441N	Bipolar latching, Hall-effect digital sensor IC, SOT-89-3L package, tape and reel packing (1000 units per reel)
CHA442NSR	A442N	Bipolar latching, Hall-effect digital sensor IC, SOT-23-3L package, tape and reel packing (3000 units per reel)
CHA442NTB	A442N	Bipolar latching, Hall-effect digital sensor IC, flat, TO-92S package, bulk packing (1000 units per bag)
CHA442NER	A442N	Bipolar latching, Hall-effect digital sensor IC, SOT-89-3L package, tape and reel packing (1000 units per reel)
CHA443NSR	A443N	Bipolar latching, Hall-effect digital sensor IC, SOT-23-3L package, tape and reel packing (3000 units per reel)
CHA443NTB	A443N	Bipolar latching, Hall-effect digital sensor IC, flat, TO-92S package, bulk packing (1000 units per bag)
CHA443NER	A443N	Bipolar latching, Hall-effect digital sensor IC, SOT-89-3L package, tape and reel packing (1000 units per reel)
CHA444NSR	A444N	Bipolar latching, Hall-effect digital sensor IC, SOT-23-3L package, tape and reel packing (3000 units per reel)
CHA444NTB	A444N	Bipolar latching, Hall-effect digital sensor IC, flat, TO-92S package, bulk packing (1000 units per bag)
CHA444NER	A444N	Bipolar latching, Hall-effect digital sensor IC, SOT-89-3L package, tape and reel packing (1000 units per reel)

	Cosemitech	CHA44X/CH44X
	Automotive Product Group	<small>. This is advanced information on a new product now in development or undergoing evaluation. Details are subject to change without notice and Cosemitech assumes no obligation for future manufacture of this product. Contact Cosemitech for the latest status.</small>

Preliminary Datasheet 2.1

1.2 CH44X is industry class product family

Part Number	Marking ID	Description
CH441SR	C441	Bipolar latching, Hall-effect digital sensor IC, SOT-23-3L package, tape and reel packing (3000 units per reel)
CH441TB	C441	Bipolar latching, Hall-effect digital sensor IC, flat, TO-92S package, bulk packing (1000 units per bag)
CH441ER	C441	Bipolar latching, Hall-effect digital sensor IC, SOT-89-3L package, tape and reel packing (1000 units per reel)
CH442SR	C442	Bipolar latching, Hall-effect digital sensor IC, SOT-23-3L package, tape and reel packing (3000 units per reel)
CH442TB	C442	Bipolar latching, Hall-effect digital sensor IC, flat, TO-92S package, bulk packing (1000 units per bag)
CH442ER	C442	Bipolar latching, Hall-effect digital sensor IC, SOT-89-3L package, tape and reel packing (1000 units per reel)
CH443SR	C443	Bipolar latching, Hall-effect digital sensor IC, SOT-23-3L package, tape and reel packing (3000 units per reel)
CH443TB	C443	Bipolar latching, Hall-effect digital sensor IC, flat, TO-92S package, bulk packing (1000 units per bag)
CH443ER	C443	Bipolar latching, Hall-effect digital sensor IC, SOT-89-3L package, tape and reel packing (1000 units per reel)
CH444SR	C444	Bipolar latching, Hall-effect digital sensor IC, SOT-23-3L package, tape and reel packing (3000 units per reel)
CH444TB	C444	Bipolar latching, Hall-effect digital sensor IC, flat, TO-92S package, bulk packing (1000 units per bag)
CH444ER	C444	Bipolar latching, Hall-effect digital sensor IC, SOT-89-3L package, tape and reel packing (1000 units per reel)
CH441NSR	441N	Bipolar latching, Hall-effect digital sensor IC, SOT-23-3L package, tape and reel packing (3000 units per reel)
CH441NTB	441N	Bipolar latching, Hall-effect digital sensor IC, flat, TO-92S package, bulk packing (1000 units per bag)
CH441NER	441N	Bipolar latching, Hall-effect digital sensor IC, SOT-89-3L package, tape and reel packing (1000 units per reel)
CH442NSR	442N	Bipolar latching, Hall-effect digital sensor IC, SOT-23-3L package, tape and reel packing (3000 units per reel)
CH442NTB	442N	Bipolar latching, Hall-effect digital sensor IC, flat, TO-92S package, bulk packing (1000 units per bag)
CH442NER	442N	Bipolar latching, Hall-effect digital sensor IC, SOT-89-3L package, tape and reel packing (1000 units per reel)
CH443NSR	443N	Bipolar latching, Hall-effect digital sensor IC, SOT-23-3L package, tape and reel packing (3000 units per reel)
CH443NTB	443N	Bipolar latching, Hall-effect digital sensor IC, flat, TO-92S package, bulk packing (1000 units per bag)
CH443NER	443N	Bipolar latching, Hall-effect digital sensor IC, SOT-89-3L package, tape and reel packing (1000 units per reel)
CH444NSR	444N	Bipolar latching, Hall-effect digital sensor IC, SOT-23-3L package, tape and reel packing (3000 units per reel)
CH444NTB	444N	Bipolar latching, Hall-effect digital sensor IC, flat, TO-92S package, bulk packing (1000 units per bag)
CH444NER	444N	Bipolar latching, Hall-effect digital sensor IC, SOT-89-3L package, tape and reel packing (1000 units per reel)

2. Pin Definitions and Descriptions

SOT-23-3L (S)	TO-92S (T)	SOT-89-3L (E)	Name	Type	Function
1	1	1	VDD	Supply	Supply Voltage pin
2	3	3	OUT	Output	Open Collector Output pin
3	2	2	GND	Ground	Ground pin

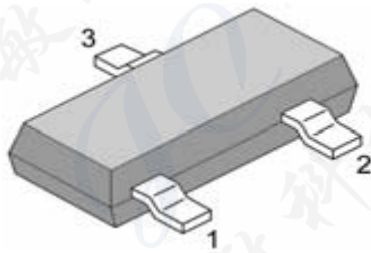
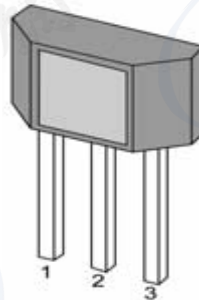
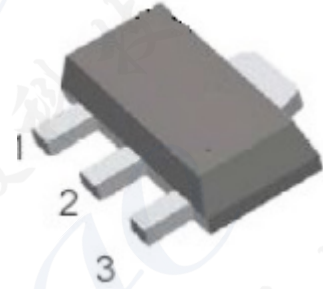
SOT-23-3L

TO-92S

SOT-89-3L

3. Absolute Maximum Ratings

Parameter	Symbol	Min	Max	Units
Supply Voltage	V_{DD}	-	24	V
VDD Reverse Voltage VDD	$V_{R_{DD}}$	-22		V
Supply Current	I_{DD}	-	20	mA
Output Voltage	V_{OUT}	-0.3	24	V
Output Current	I_{OUT}	-	25	mA
Operating Ambient Temperature	T_A	-40	150	°C
Storage Temperature	T_S	-55	165	°C
Junction temperature	T_J	-55	165	°C
Magnetic Flux	B	No Limit		Gauss

Note: Exceeding the absolute maximum ratings may cause permanent damage. Exposure to absolute-maximum-rated conditions for extended periods may affect device reliability.

4. ESD Protections

Parameter	Value	Unit
All pins ¹⁾	+/-8000	V
All pins ²⁾	+/-200	V
All pins ³⁾	+/-750	V

1) HBM (Human Body Mode) according to AEC-Q100-002

2) MM (Machine Mode) according to AEC-Q100-003

3) CDM (charged device mode) according to AEC-Q100-011

	Cosemitech	CHA44X/CH44X
	Automotive Product Group	. This is advanced information on a new product now in development or undergoing evaluation. Details are subject to change without notice and Cosemitech assumes no obligation for future manufacture of this product. Contact Cosemitech for the latest status.

Preliminary Datasheet 2.1

5. Function Description

The CHA44X/CH44X exhibits latch magnetic switching characteristics. Therefore, it requires both south and north poles to operate properly.

The device behaves as a latch with symmetric operating and release switching points ($BOP=|BRP|$). This means magnetic fields with equivalent strength and opposite direction drive the output high and low.

Removing the magnetic field ($B \rightarrow 0$), it keeps the output in its previous state. This latching property defines the device as a magnetic memory.

A magnetic hysteresis BHYST keeps BOP and BRP separated by a minimal value. This hysteresis prevents output oscillation near the switching point.

6. Magnetic Activation

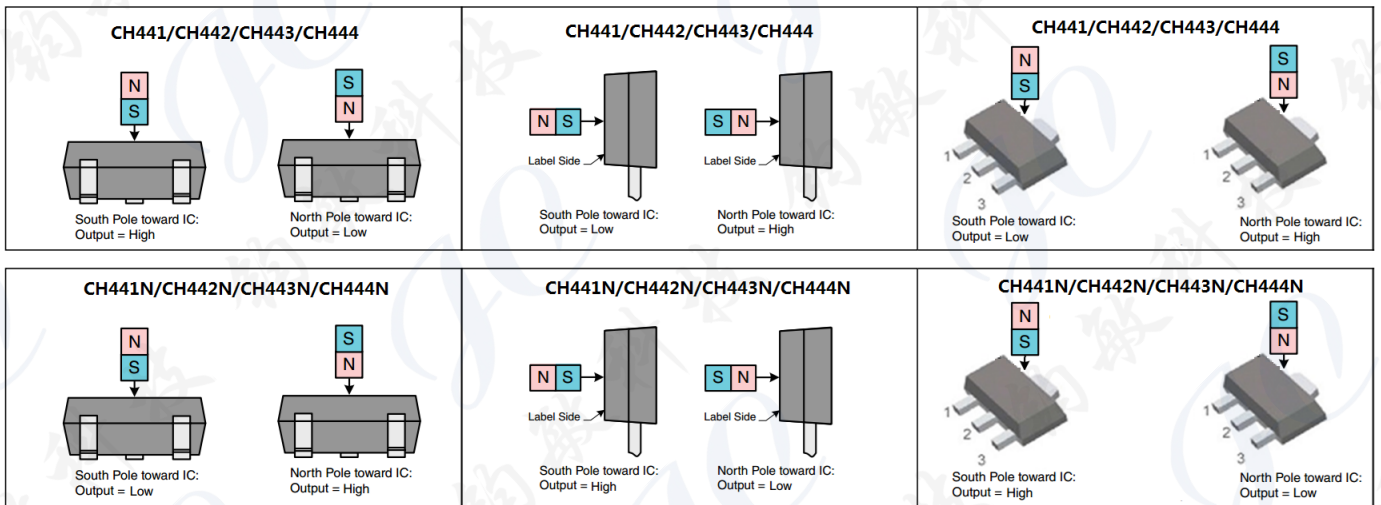

7. Temperature & Voltage Characteristics

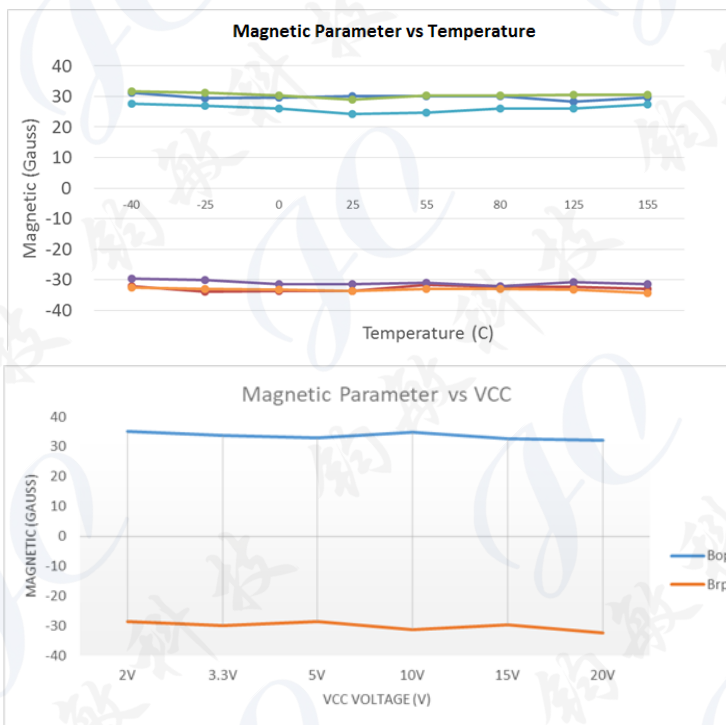

Note: the magnetic parameter @VCC=2V is test at condition: rise the VCC to 2.5V, then drop down the VCC voltage to 2V.



Cosemitech

CHA44X/CH44X

Automotive Product Group

This is advanced information on a new product now in development or undergoing evaluation. Details are subject to change without notice and Cosemitech assumes no obligation for future manufacture of this product. Contact Cosemitech for the latest status.

Preliminary Datasheet 2.1

8. Parameters Specification (VCC=3.3V supply, TA= -40 °C to 150 °C except where otherwise specified.)

Symbol	Parameter	Test Condition	Min	Typ.	Max	Units
V _{CC}	Supply voltage	-40 °C to 150 °C	2.5	-	22	V
V _{CCL} ⁽¹⁾	Lowest supply voltage	-40 °C to 150 °C	2			V
I _{DD}	Supply Current	V _{DD} = 2.5V to 22V	-	1.6	3	mA
V _{ZSUPPLY}	Supply Zener Clamp Voltage	I _{CC} = 7 mA; TA = 25°C	24			V
V _{ZOUT}	Output Zener Clamp Voltage	I _{OUT} = 3mA	24			V
V _{RCC}	Reverse Battery Zener				-22	V
I _{RCC}	Reverse Battery Current	V _{CC} = -22 V	-5			mA
F _C	Chopping Frequency			500		KHz
t _{PO}	Power-On Time	TA = 25°C; C _{LOAD} = 10 pF	-	-	30	µs
V _{DSon}	Output saturation voltage	at 20mA, Gauss >BOP	-	-	0.4	V
I _{OFF}	Output Leakage Current	V _{OUT} = 24 V; Switch state = Off	-	-	10	uA
I _{OUT(lim)}	Output Current Limit	Short-Circuit Protection	30	-	90	mA
T _R	Output rise time	R _{LOAD} = 820 Ω, C _{LOAD} = 10 pF;	-	0.2	2	uS
T _F	Output fall time	R _{LOAD} = 820Ω, C _{LOAD} = 10 pF;	-	0.1	2	uS
T _d	Output delay Time	B=Brp-100G to Bop+100G in 1us		13	25	µs
R _{TH}	Thermal resistance: SOT-23-3L TO-92S SOT-89-3L	-	-	303 203 230	-	°C/W °C/W °C/W
F _{SW} ⁽²⁾	Maximum Switching Frequency		20	30		KHz
T	Operating temperature	-	-40	-	150	°C
T _S	Storage temperature:	-	-40	-	150	°C
CHA441/CH441						
B _{OP}	Magnetic operating point	T _A =-40°C to 150°C	6	15	36	Gauss
B _{RP}	Magnetic release point	T _A =-40°C to 150°C	-36	-15	-6	Gauss
B _{HYST}	Magnetic hysteresis window BOP-BRP	T _A =-40°C to 150°C	12	30	50	Gauss
B _O	Magnetic offset; B _O = (BOP + BRP) / 2	T _A =-40°C to 150°C	-15	0	15	Gauss
CHA442/CH442						
B _{OP}	Magnetic operating point	T _A =-40°C to 150°C	10	30	50	Gauss
B _{RP}	Magnetic release point	T _A =-40°C to 150°C	-50	-30	-10	Gauss
B _{HYST}	Magnetic hysteresis window BOP-BRP	T _A =-40°C to 150°C	35	60	85	Gauss
B _O	Magnetic offset; B _O = (BOP + BRP) / 2	T _A =-40°C to 150°C	-15	0	15	Gauss
CHA443/CH443						

	Cosemitech	CHA44X/CH44X
	Automotive Product Group	<small>. This is advanced information on a new product now in development or undergoing evaluation. Details are subject to change without notice and Cosemitech assumes no obligation for future manufacture of this product. Contact Cosemitech for the latest status.</small>

Preliminary Datasheet 2.1

B_{OP}	Magnetic operating point	T _A =-40°C to 150°C	20	45	75	Gauss
B_{RP}	Magnetic release point	T _A =-40°C to 150°C	-75	-45	-20	Gauss
B_{HYST}	Magnetic hysteresis window B _{OP} -B _{RP}	T _A =-40°C to 150°C	70	90	110	Gauss
B_O	Magnetic offset; B _O = (B _{OP} + B _{RP}) / 2	T _A =-40°C to 150°C	-20	0	20	Gauss
CHA444/CH444						
B_{OP}	Magnetic operating point	T _A =-40°C to 150°C	70	120	180	Gauss
B_{RP}	Magnetic release point	T _A =-40°C to 150°C	-180	-120	-70	Gauss
B_{HYST}	Magnetic hysteresis window B _{OP} -B _{RP}	T _A =-40°C to 150°C	180	240	300	Gauss
B_O	Magnetic offset; B _O = (B _{OP} + B _{RP}) / 2	T _A =-40°C to 150°C	-30	0	30	Gauss
CHA441N/CH441N						
B_{OP}	Magnetic operating point	T _A =-40°C to 150°C	-36	-15	-6	Gauss
B_{RP}	Magnetic release point	T _A =-40°C to 150°C	6	15	36	Gauss
B_{HYST}	Magnetic hysteresis window B _{OP} -B _{RP}	T _A =-40°C to 150°C	15	30	50	Gauss
B_O	Magnetic offset; B _O = (B _{OP} + B _{RP}) / 2	T _A =-40°C to 150°C	-15	0	15	Gauss
CHA442N/CH442N						
B_{OP}	Magnetic operating point	T _A =-40°C to 150°C	-50	-30	-10	Gauss
B_{RP}	Magnetic release point	T _A =-40°C to 150°C	10	30	50	Gauss
B_{HYST}	Magnetic hysteresis window B _{OP} -B _{RP}	T _A =-40°C to 150°C	35	60	85	Gauss
B_O	Magnetic offset; B _O = (B _{OP} + B _{RP}) / 2	T _A =-40°C to 150°C	-15	0	15	Gauss
CHA443N/CH443N						
B_{OP}	Magnetic operating point	T _A =-40°C to 150°C	-75	-45	-20	Gauss
B_{RP}	Magnetic release point	T _A =-40°C to 150°C	20	45	75	Gauss
B_{HYST}	Magnetic hysteresis window B _{OP} -B _{RP}	T _A =-40°C to 150°C	70	90	110	Gauss
B_O	Magnetic offset; B _O = (B _{OP} + B _{RP}) / 2	T _A =-40°C to 150°C	-20	0	20	Gauss
CHA444N/CH444N						
B_{OP}	Magnetic operating point	T _A =-40°C to 150°C	-180	-120	-70	Gauss
B_{RP}	Magnetic release point	T _A =-40°C to 150°C	70	120	180	Gauss
B_{HYST}	Magnetic hysteresis window B _{OP} -B _{RP}	T _A =-40°C to 150°C	180	240	300	Gauss
B_O	Magnetic offset; B _O = (B _{OP} + B _{RP}) / 2	T _A =-40°C to 150°C	-30	0	30	Gauss

(1) Here the lowest voltage is refer to the operation supply voltage after the chip power on, such as: rise the VCC to 2.5V, then drop down the VCC voltage to 2V.

(2) 1 mT = 10 Gauss

(3) Bandwidth describes the fastest changing magnetic field that can be detected and translated to the output.

NOTICE

The magnetic field strength (Gauss) required to cause the switch to change state (operate and release) will be as specified in the magnetic characteristics. To test the switch against the specified magnetic characteristics, the switch must be placed in a uniform magnetic field.

9. Application Information

9.1 Typical Application

It is recommended that an external capacitor C1 is connected to the supply. This can reduce the noise injected into the device. Normal 0.1µF is suggested.

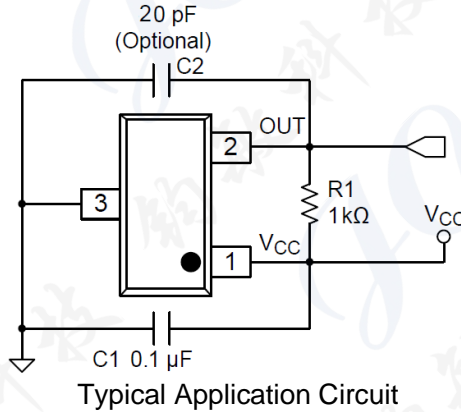

9.2 Device Output

If the device is powered on with a magnetic field strength between BRP and BOP, then the device output is indeterminate and can either be Hi-Z or Low. If the field strength is greater than BOP, then the output is pulled low. If the field strength is less than BRP, then the output is released.

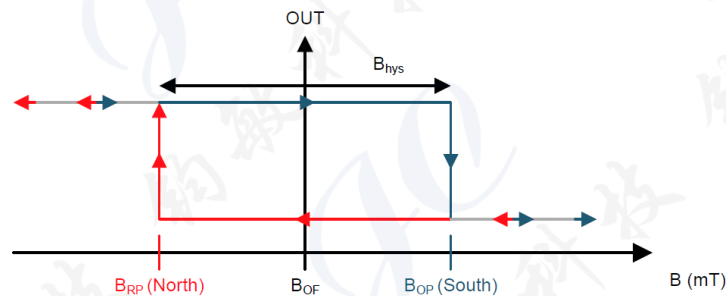

9.3 Output Stage

The CH44X output stage uses an open-drain NMOS, and it is rated to sink up to 30 mA of current. For proper operation, calculate the value of the pullup resistor R1 using Equation 1.

$$\frac{V_{ref\ max}}{30\ mA} \leq R1 \leq \frac{V_{ref\ min}}{100\ \mu A} \quad (1)$$

The size of R1 is a tradeoff between the OUT rise time and the current when OUT is pulled low. A lower current is generally better, however faster transitions and bandwidth require a smaller resistor for faster switching. In addition, ensure that the value of R1 > 500 Ω to ensure the output driver can pull the OUT pin close to GND.

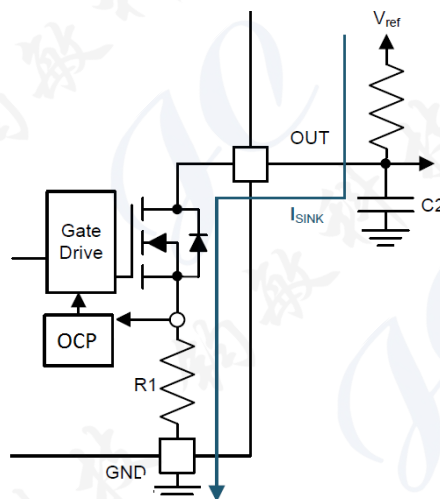

	Cosemitech	CHA44X/CH44X
	Automotive Product Group	<small>. This is advanced information on a new product now in development or undergoing evaluation. Details are subject to change without notice and Cosemitech assumes no obligation for future manufacture of this product. Contact Cosemitech for the latest status.</small>

Preliminary Datasheet 2.1

Select a value for C2 based on the system bandwidth specifications as shown in [Equation 2](#).

$$2 \times f_{BW} \text{ (Hz)} < \frac{1}{2\pi \times R1 \times C2} \quad (2)$$

Most applications do not require this C2 filtering capacitor.

9.4 Protection Circuits

The CH44X device is fully protected against overcurrent and reverse-supply conditions.

9.5 Overcurrent Protection (OCP)

An analog current-limit circuit limits the current through the FET. The driver current is clamped to IOCP. During this clamping, the rDS(on) of the output FET is increased from the nominal value.

9.6 Reverse Supply Protection

The CH44X device is protected in the event that the VCC pin and the GND pin are reversed (up to -22 V).

9.7 Alternative Two-Wire Application

For systems that require minimal wire count, the device output can be connected to VCC through a resistor, and the total supplied current can be sensed near the controller.

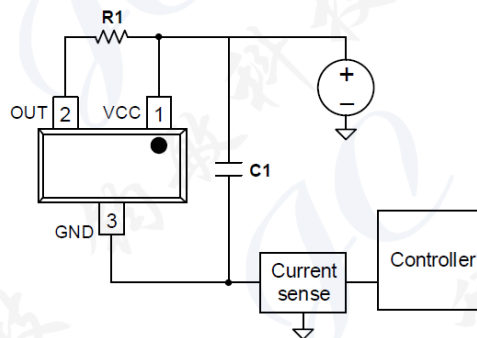

2-Wire Application

Current can be sensed using a shunt resistor or other circuitry.

10. Test Conditions

Note: DUT=Device Under Test

Supply Current

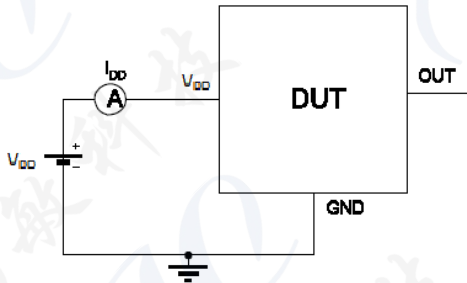

Note 1 - The supply current I_{DD} represents the static supply current. OUT is left open during measurement

Note 2 - The device is put under magnetic field with $B < B_{RP}$

Output Saturation Voltage

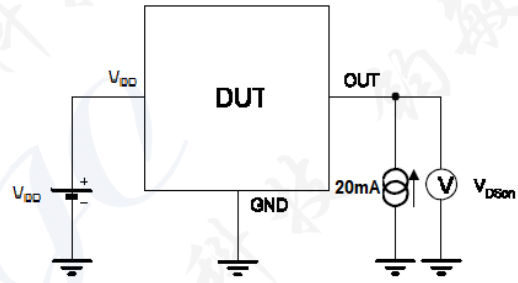

Note 1 - The output saturation voltage $V_{DS(on)}$ is measured at $V_{DD}=3.3V$ and $V_{DD}=20V$

Note 2 - The device is put under magnetic field with $B > B_{OP}$

Output Leakage Current

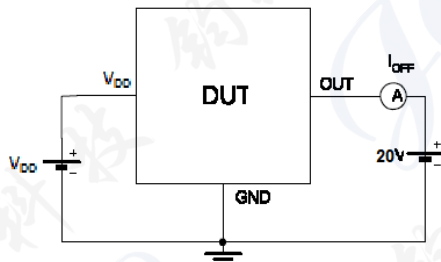

Note 1 - The device is put under magnetic field with $B < B_{RP}$

Magnetic Thresholds

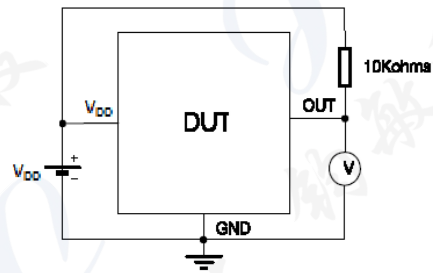

Note 1 - B_{OP} is determined by putting the device under magnetic field swept from B_{RPmin} up to B_{OPmax} until the output is switched on.

Note 2 - B_{RP} is determined by putting the device under magnetic field swept from B_{OPmax} down to B_{RPmin} until the output is switched off.

11. Package Information:

**Package Designator
TO-92S**

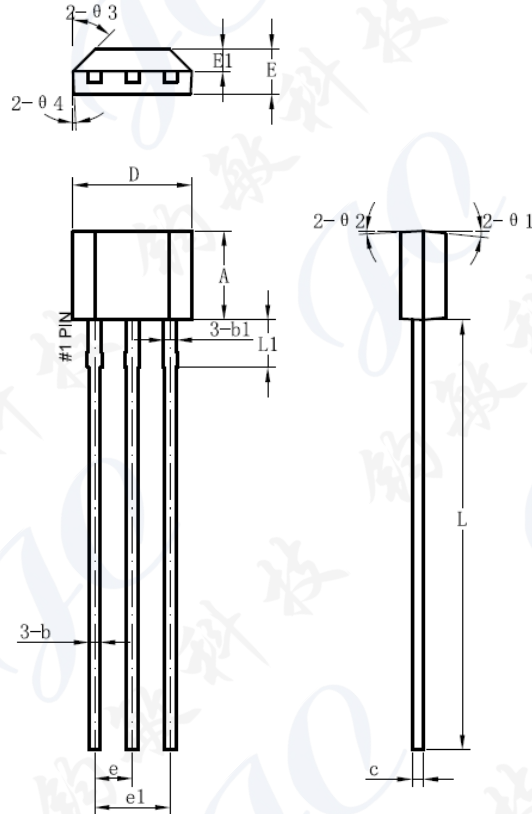

Symbol	Dimensions in Millimeters		
	Min.	Typ.	Max.
A	2.9	3	3.1
b	0.35	0.39	0.56
b1		0.44	
c	0.36	0.38	0.51
D	3.9	4	4.1
E	1.42	1.52	1.62
E1		0.75	
e		1.27	
e1		2.54	
L	13.5	14.5	15.5
L1		1.6	
$\theta 1$		6°	
$\theta 2$		3°	
$\theta 3$		45°	
$\theta 4$		3°	

PACKAGE DESIGNATOR
SOT-23-3L

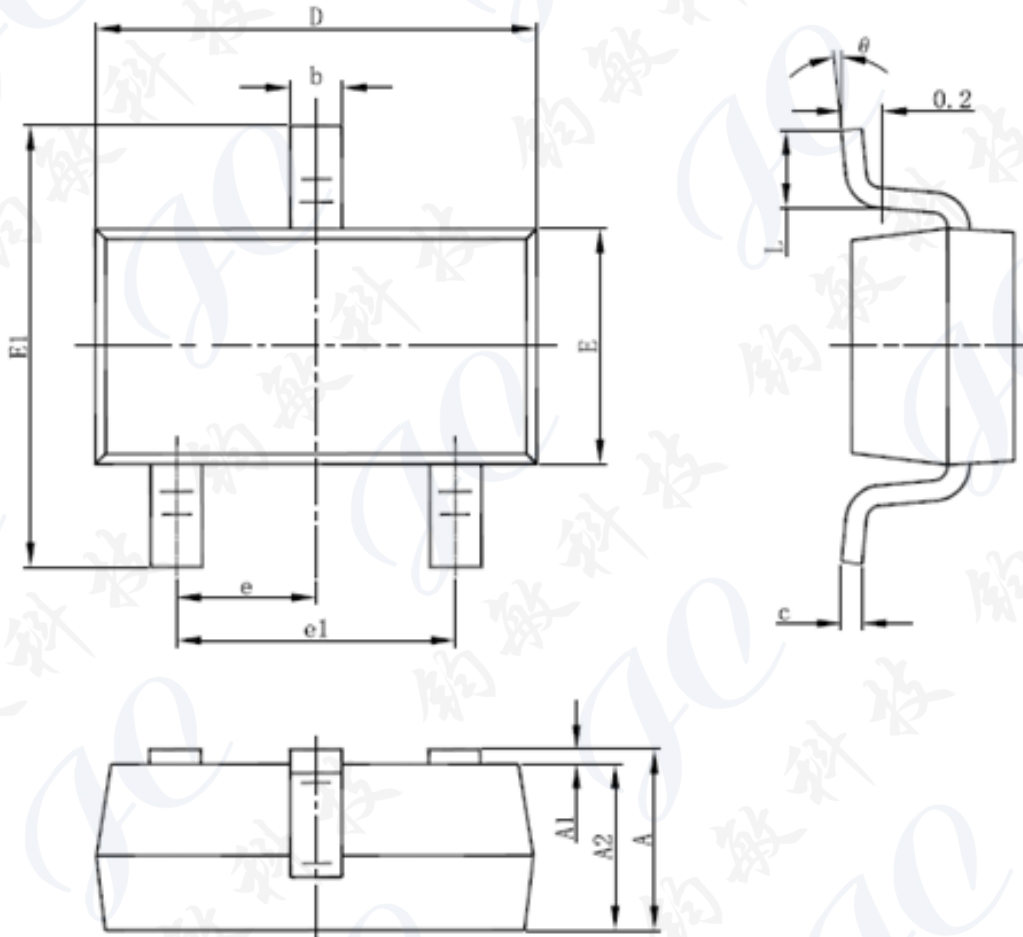

Symbol	Dimensions In Millimeters		Dimensions In Inches	
	Min	Max	Min	Max
A	1.050	1.250	0.041	0.049
A1	0.000	0.100	0.000	0.004
A2	1.050	1.150	0.041	0.045
b	0.300	0.500	0.012	0.020
c	0.100	0.200	0.004	0.008
D	2.820	3.020	0.111	0.119
E	1.500	1.700	0.059	0.067
E1	2.650	2.950	0.104	0.116
e	0.950(BSC)		0.037(BSC)	
e1	1.800	2.000	0.071	0.079
L	0.300	0.600	0.012	0.024
θ	0°	8°	0°	8°

PACKAGE DESIGNATOR
SOT-89-3L

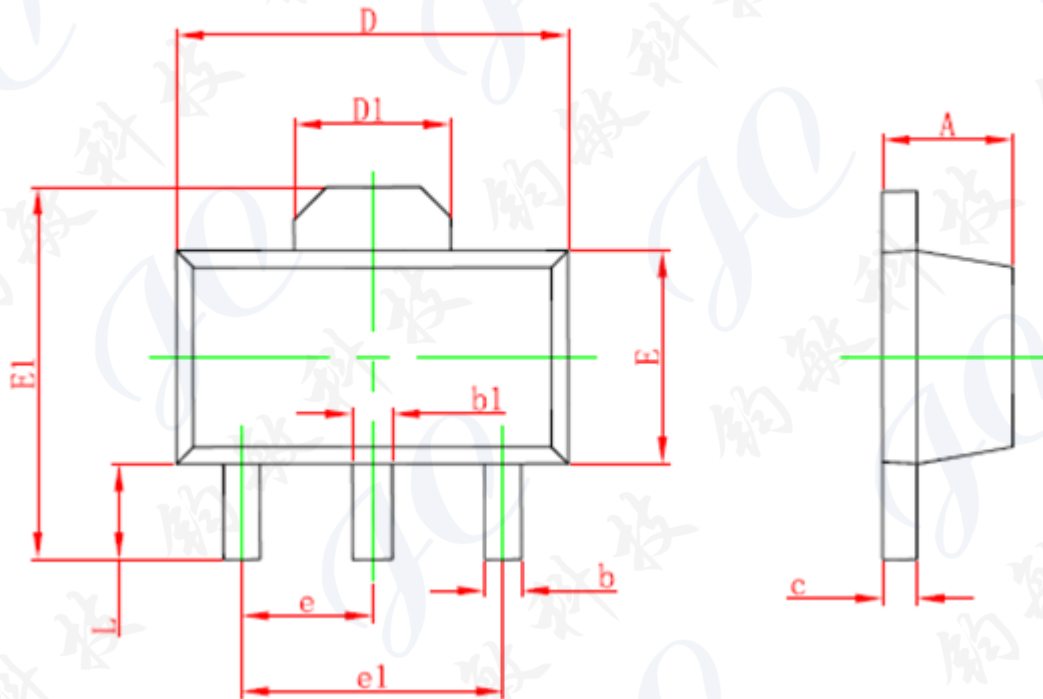

Symbol	Dimensions In Millimeters		Dimensions In Inches	
	Min.	Max.	Min.	Max.
A	1.400	1.600	0.055	0.063
b	0.320	0.520	0.013	0.020
b1	0.400	0.580	0.016	0.023
c	0.350	0.440	0.014	0.017
D	4.400	4.600	0.173	0.181
D1	1.550 REF.		0.061 REF.	
E	2.300	2.600	0.091	0.102
E1	3.940	4.250	0.155	0.167
e	1.500 TYP.		0.060 TYP.	
e1	3.000 TYP.		0.118 TYP.	
L	0.900	1.200	0.035	0.047

	Cosemitech	CHA44X/CH44X
	Automotive Product Group	<small>This is advanced information on a new product now in development or undergoing evaluation. Details are subject to change without notice and Cosemitech assumes no obligation for future manufacture of this product. Contact Cosemitech for the latest status.</small>

Preliminary Datasheet 2.1

Information furnished is believed to be accurate and reliable. However, Cosemitech assumes no responsibility for the consequences of use of such information nor for any infringement of patents or other rights of third parties which may result from its use. No license is granted by implication or otherwise under any patent or patent rights of Cosemitech. Specification mentioned in this publication are subject to change without notice. This publication supersedes and replaces all information previously supplied. Cosemitech products are not authorized for use as critical components in life support devices or systems without express written approval of Cosemitech.

The Cosemitech logo is a registered trademark of Cosemitech